



-
-
- R15
- Total Station
- **User Manual**
-



(August 2018)-Ver.1-Rev.1 – Firmware Version: 18-05-29



Dear Customer:

Congratulations! We, STONEX, are proud to present you with these series instrument.

Your total station is a rugged and reliable instrument whose performance and design are not surpassed.

To fully appreciate and protect your investment, we suggest that you take the necessary time to read and fully understand this manual. We have a dedicated service organization. If the need arises, please don't hesitate to contact us.

Thank you for your trust and confidence.

Contents

1. Precautions for safety	3
1.1. Note.....	3
1.2. Definition of indication.....	4
1.3. Safety standards for laser.....	5
1.4. About user.....	6
1.5. Exceptions from responsibility.....	6
2. Nomenclature	7
2.1. Parts of the instrument.....	7
2.2. Keyboard.....	9
3. Preparation before measurement	10
3.1. Power on/off.....	10
3.2. About battery.....	11
3.3. Setting up the instrument.....	13
3.4. Centering and levelling-up.....	14
3.5. Assembling and disassembling for three-jaws tribrach.....	16
4. Basic functions	17
4.1. Display.....	17
4.2. Mode diagram.....	18
4.3. How to input number and alphabet.....	20
4.4. How to select in research mode.....	20
5. Instrument settings	21
5.1. How to configure.....	21
5.2. EDM settings.....	22
5.3. How to set parameters.....	24
6. Measurement	32
6.1. Angle measurement.....	32
6.2. Distance measurement.....	34
7. Pre-survey operations	35
7.1. Set a job.....	35
7.2. Set the station.....	35
8. Survey programs	38
8.1. Coordinate measurement.....	38
8.2. Stake out measurement.....	41
8.3. Area.....	45
8.4. Offset measurement.....	47
8.5. MLM.....	51
8.6. REM.....	53
8.7. Resection.....	54
8.8. Point projection.....	59
8.9. Stake out line.....	61
8.10. Traverse surveying.....	65
8.11. Inverse.....	67

8.12. Polar coordinates calculation.....	68
8.13. Repetition angle measurement.....	69
8.14. Arc staking out measurement.....	71
8.15. Road staking out measurement.....	77
9. Record.....	91
9.1. Record occupied data.....	91
9.2. Collect angle data.....	92
9.3. Collect points.....	92
9.4. Record note.....	93
9.5. View data.....	94
9.6. Job selection.....	94
10. Data management.....	95
10.1. Job management.....	95
10.2. Known data management.....	99
10.3. Code management.....	102
10.4. Storage media select.....	104
10.5. Connect PC via USB port.....	105
11. Check and adjustment.....	106
11.1. The instrument constant.....	106
11.2. Plate level.....	107
11.3. Circular level.....	107
11.4. The optical sight.....	108
11.5. Laser plummet.....	109
11.6. Vertical cross-hair on telescope.....	109
11.7. Tilt sensor.....	110
11.8. Horizontal collimation error C.....	112
11.9. Vertical index error.....	113
11.10. EDM optical axis and the telescope sighting axis error.....	115
12. Warning and error messages.....	117
13. Technical features.....	118
14. Kit components.....	119
Appendix I: Atmospheric correction formula and chart.....	120
Appendix II: Correction for refraction and earth curvature.....	122
Appendix III: Technical drawing.....	123
Limited warranty standard.....	124
FCC statements.....	127
Environmental recycling.....	128

1. Precautions for safety

1.1. Note

Don't collimate the sun directly

Avoid insulating the instrument, and don't collimate the sun directly for protecting eyes and instrument.

Avoid the vibrations on the instrument

When transporting, keep the instrument in the case and try your best to lighten vibrations.

Carry the instrument

When carrying, the instrument handle must be hold tight.

Check the battery power

Before using it, you should check the power whether it is enough.

Battery maintenance

If the instrument is not used for a long time, the battery should be taken out from the instrument and stored in separate place. Meantime, the battery should be charged every month.

Take out the battery

It is not suggested to take out the battery when the instrument is on, otherwise, the stored data may be lost, so it is better to replace the battery after power off the instrument.

Set up the instrument on the tripod

When using it please insure the connection between tripod and instrument is firm. It is better to work with wooden tripod for the measurement accuracy.

Assemble the tribrach on the instrument

The setting of tribrach would influence the accuracy. The tribrach should be check frequently, the screw which connects the tribrach and alidade must be locked tightly. And the central fixing screw should be tight.

High temperature condition

Don't put the instrument in high temperature condition for a long time, it is bad for the instrument performance.

Temperature changing sharply

The sharp temperature changing on the instrument or prism will shorten the distance measurement range, for example, after taking the instrument out from a warm car to a cold condition, wait for some time, it can be used when it adapts the surrounding condition.

The noise from the instrument

When the instrument working, it is normal if you hear the noise from instrument motor, it will not affect the instrument work.



Stored data responsibility

STONEX should not be held liable for the lost data because of wrong operation.

1.2. Definition of indication

For the safe of your product and prevention of injury to operators and other persons as well as prevention of property damage, items which should be observed are indicated by an exclamation point within a triangle used with WARNING and CAUTION statements in this manual.

The definitions of the indication are listed below. Be sure you understand them before reading the manual's main text.

	WARNING:	Ignoring this indication and making an operation error could possibly result in death or serious injury to the operator.
	CAUTION:	Ignoring this indication and making an operation error could possibly result in death or serious injury to the operator



WARNING:

- Do not perform disassembly or rebuilding. Fire, electric shock or burns could result. Only STONEX authorized distributors can disassemble or rebuilt.
- Do not collimate the sun directly. The eye injury or blind could result.
- Do not cover the charger. Fire could be result.
- Do not use defection power cable, socket or plug. Fire, electronic shock could result.
- Do not use wet battery or charger. Fire, electronic shock could result.
- Do not close the instrument to burning gas or liquid, and do not use the instrument in coal mine. Blast could be result.

- Do not put the battery in the fire or high temperature condition. Explosion, damage could result.
- Do not use the battery which is not specified by STONEX. Fire, electric shock or burn could result.
- Do not use the power cable which is not specified by STONEX. Fire could result.
- Do not short circuit of the battery. Fire could result.
- When this product encounters disturbance of severe Electrostatic Discharge, perhaps it will have some degradation of performance like switching on/off automatically and so on.



CAUTION:

- Do not touch the instrument with wet hand. Electric shock could result.
- Do not touch the instrument with wet hand. Electric shock could result.
- Do not stand or seat on the carrying case, and do not turn over the carrying case arbitrarily, the instrument could be damaged.
- Be careful of the tripod tiptoe when setup or move it.
- Do not drop the instrument or the carrying case, and do not use defective belt, agraffe or hinge. Instrument damage could result.
- Do not touch liquid leaking from the instrument or battery. Harmful chemicals could cause burn or blisters.
- Please assemble the tribrach carefully, if the tribrach is not stable, series damage could result.
- Do not drop the instrument or tripod, series damage could result. Before use it, check the central screw is tight.

1.3. Safety standards for laser

R15 series adopt the class of Laser Product according to IEC Standard Publication 60825-1 Amd. 2:2001. According this standard, EDM device is classified as Class 3R Laser Product when reflectorless measurement is selected, when the prism and reflective sheet is selected as target, the output is equivalent to the safer class 1. Follow the safety instructions on the labels to ensure safe use.

CAUTION: CLASS 3R LASER RADIATION WHEN OPEN
AVOID DIRECT EYE EXPOSURE.

CAUTION: CLASS 2 LASER RADIATION WHEN OPEN
DO NOT STARE INTO THE BEAM



NOTE FOR SAFETY

	<h2>WARNING</h2>
<ul style="list-style-type: none">• Never point the laser beam at other's eyes, it could cause serious injury.• Never look directly into the laser beam source, it could cause permanent eye damage.• Never stare at the laser beam, it could cause permanent eye damage.• Never look at the laser beam through a telescope or other optical devices, it could cause permanent eye damage.	

1.4. About user

This product is for professional use only!

1. The user is required to be a qualified surveyor or have a good knowledge of surveying, in order to understand the user manual and safety instructions, before operating, inspecting or adjusting.
2. Wear required protectors (safety shoes, helmet, etc.) when operating.

1.5. Exceptions from responsibility

- The user of this products is expected to follow all operating instructions and make periodic checks of the product's performance.
- The manufacturer assumes no responsibility for results of a faulty or intentional usage or misuse including any direct, indirect, consequential damage, and loss of profits.
- The manufacturer assumes no responsibility for consequential damage, and loss of profits by any disaster, (an earthquake, storms, floods, etc.).
- The manufacturer assumes no responsibility for any damage, and loss of profits due to a change of data, loss of data, an interruption of business etc., caused by using the product or an unusable product.
- The manufacturer assumes no responsibility for any damage, and loss of profits caused by usage except for explained in the user manual.
- The manufacturer assumes no responsibility for damage caused by wrong transport, or action due to connecting with other products.

2. Nomenclature

2.1. Parts of the instrument





2.2. Keyboard



Keys	Description
F1~F4	Select the functions matching the soft-keys
0~9	Input number when numeric input Input characters when alphabetic input
•	Input a decimal point
±	Input plus/minus sign
Power	Power on/off
★	Enter setting mode directly
ESC	Escape to the previous menu or mode
SFT	<ul style="list-style-type: none"> • Shift between number and alphabetic when inputting • Shift targets model when measuring
BS	<ul style="list-style-type: none"> • Delete the character at the left of the cursor when inputting • Open electronic level menu
Space	<ul style="list-style-type: none"> • Input a black space when inputting • Input the target or instrument height
Func	Turn page
ENT	<ul style="list-style-type: none"> • Select/Accept input data • Accept the option when selecting

3. Preparation before measurement

3.1. Power on/off

Power on



Confirm the instrument is leveling, press the red {POWER} key.

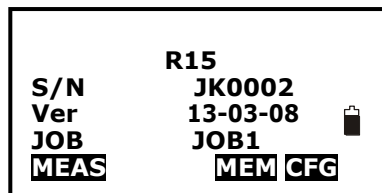

The instrument will power on and display the status screen

Power off



Press {POWER} key, the instrument will ask you to turn off the instrument or not, press F3[YES], it will be turned off, press F4[NO] back to previous screen.

3.2. About battery



3.2.1. Battery power symbol

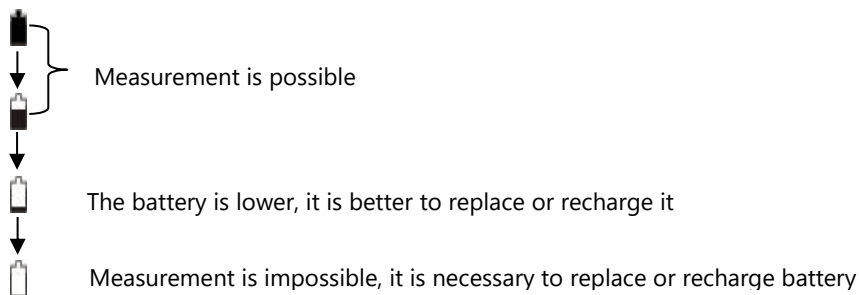

NOTE:

- The working time of battery will be affected by many factors, such as ambient temperature, recharging time, recharging and discharging times. On the data safe side, we suggest the users recharge the battery full or prepare several full batteries before operation.
- The battery symbol only indicates power capability for current measurement mode. The power consumption in distance measurement mode is more than in angle mode, if the instrument enters into distance measurement mode from angle mode, the power maybe auto-off because of lower battery.
- The symbol only indicates the supply power but not the instantaneous power change. And if the measurement mode changes, the symbol will not show the power's decrease or increase immediately.
- It is suggested to check every battery power before field work.

3.2.2. Replace the battery



1) Remove the battery

- Press the button downward as shown left
- Remove the battery by pulling it toward you

2) Mount the battery

- Insert the battery to the instrument
- Press the top of the battery until you hear a Click.

3.2.3. Recharge the battery



As the figure shows, connect the charger and the battery, then plug the charger into the outlet of 100V-240V AC power supply, recharging will begin.

NOTE:

- For a new (or long time no use) battery, in order to fully extend its capacity, it is absolutely necessary to carry out 3 to 5 complete charging/discharging cycles, and the charging time must be 10 hours at least each time.
- The indicator light on the charger will illuminate three separate colors for varies mode conditions:
 - Solid Red Light — indicates that the charger is working;
 - Solid Green Light — indicates that the charge has finished;
 - Flashing Red Light — indicates no battery on charging; poor connection or some problems exist.
- It is recommended to continue charging for 1 or 2 hours after the light turns green.
- Once the red-light flashes constantly after the charger is plugged into the outlet of 100V-240V AC power supply, please remove the battery and reconnected it after 3 or 5 min.

3.3. Setting up the instrument

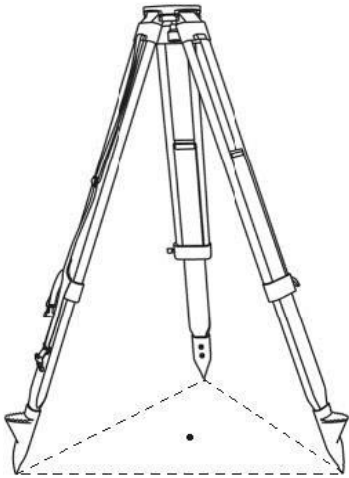

- 1) Set up the tripod first: extend the extension legs to suitable lengths and tighten the screws on the midsections. Make sure the legs are spaced at equal intervals and the head is approximately level. Set the tripod so that the head is positioned over the surveying point. Make sure the tripod shoes are firmly fixed in the ground.

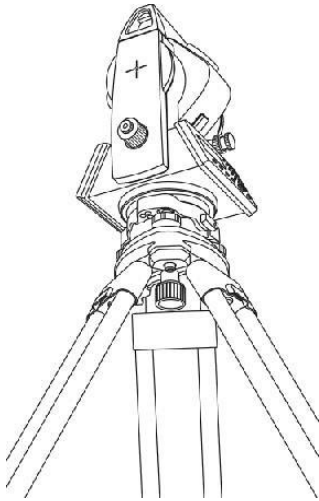

- 2) Mount the instrument on the tripod head. Supporting it with one hand, tighten the centering screw on the bottom of the unit to make sure it is secured to the tripod.

3.4. Centering and levelling-up

Basic levelling-up with the circular level

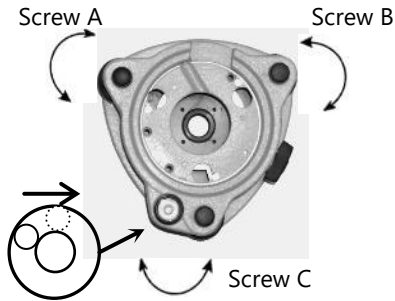

Move the foot screws A and B in opposite direction till the circular bubble is perpendicular to a line shaped with screw A and B. The direction of rotation in left thumb indicates the movement of the circular bubble.

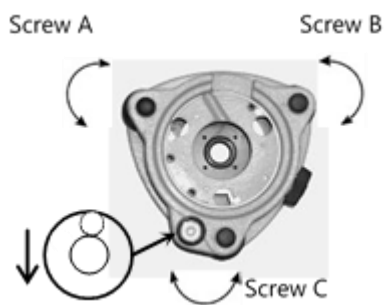

Move the bubble to the center of the circle by turning screw C.

Accurate levelling-up with the plate level

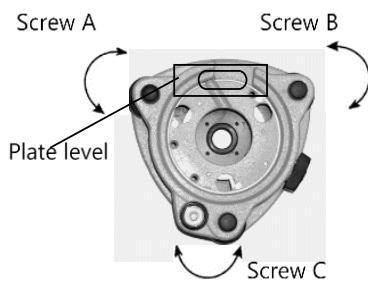

Loosen the horizontal motion clamp and turn the instrument till the plate level is parallel to a line shaped with screws A and B. Adjust the screws A and B to make the bubble in the center of the level.

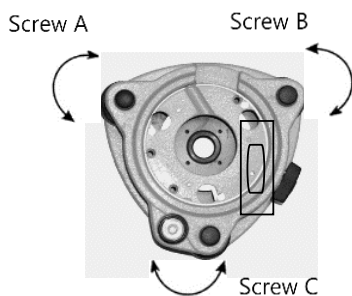

Turn the instrument approximately 90°. Adjust screw C, till the bubble in the center of the level.

Repeat above steps until the bubble remains in the center of the plate level while the instrument is rotated to any position.

Accurate levelling-up with electronic level on screen

It is convenient for R15 series to level-up with electronic level, especially when it is difficult to observe the circular level and plate level.

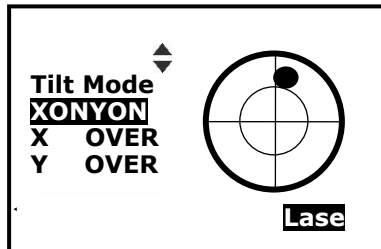

Power on the instrument and press {BS} key directly, and the electric level displays on screen.

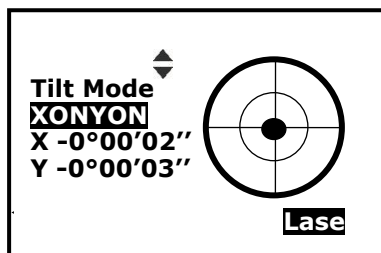

Level it by turning three-foot screws, see above operation "3. Center the bubble in the plate level".

NOTE:

- On this menu you can turn on/off the X/Y compensator by pressing ▲/▼ keys.
- If the instrument is equipped with laser plummet, after opening this menu, press {F4} and laser plummet adjusting bar will display. With pressing ◀/▶ keys the laser lightness can be adjusted.

Centering with laser plummet

External influences and the surface conditions may lead to the requirement of the adjustment of the laser intensity. After activating electronic level, press F4[Lase] and the laser plummet adjusting bar will display.

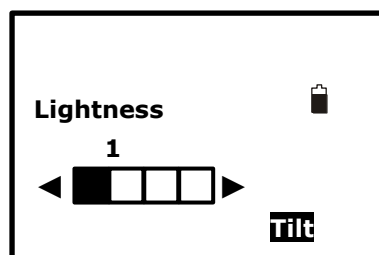

With pressing ◀/▶ keys you can turn on or off laser plummet and set it as four levels (25% steps) of brightness. Thus, that laser emits downwards can be seen.

Loosen the center screw of tripod, and move the base plate on tripod head until the laser spot coincides with ground mark point. Then tighten the center screw.

Repeat leveling and two steps until the instrument keeps leveling and the laser spot coincides with ground mark point when rotating alidade of instrument in any direction.

After centering, please turn off laser plummet to save power.

3.5. Assembling and disassembling for three-jaws tribrach

It is convenient to assemble or disassemble the instrument from tribrach by loosen or tighten the tribrach clamp.

Disassemble

Rotate the tribrach clamp anticlockwise until the lever is loosen.

One hand holds up the tribrach, another hand holds the carry handle of the instrument and lift out the instrument from the tribrach.

Assemble

Put the instrument into the tribrach lightly, let the communication port against in the indentation of the tribrach.

Rotate the tribrach clamp clockwise until the lever is tighten.

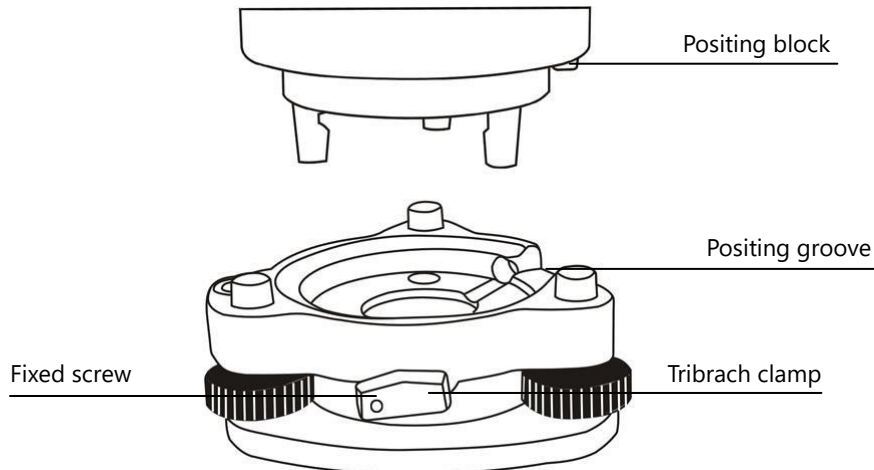

NOTE: Fix the tribrach clamp: if the instrument doesn't need assembly or disassembly from tribrach frequently, it is necessary to fix the tribrach clamp by fixed screw to avoid the disassembly by accident.

Screw out the fixed screw by driver to fix the clamp.

4. Basic functions

4.1. Display

The LCD could display 6 lines with 20 characters per line. In measurement mode, it displays some common information in above 5 lines and displays soft functions in the last line.

NOTE: Do not touch the screen with sharp things.



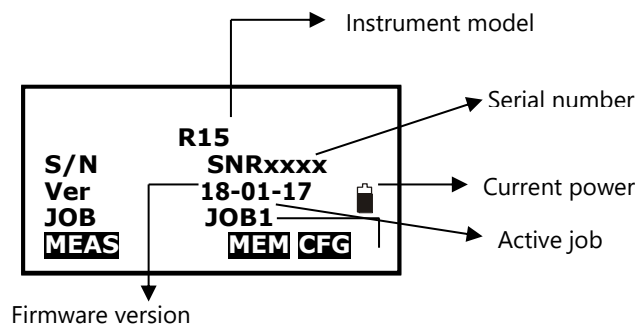

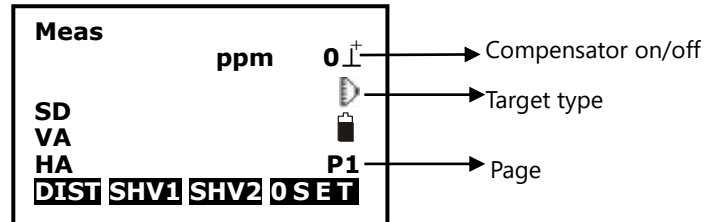

Status screen



Basic measure mode



Symbols:

	Symbol	Description
Current power		Level of the remaining battery
Compensator mode		The compensator is on
Target type		Distance measurements with prism
		Long range distance measurements with prism
		Distance measurements with sheet
		Distance measurements with no prism

4.2. Mode diagram

Measure mode

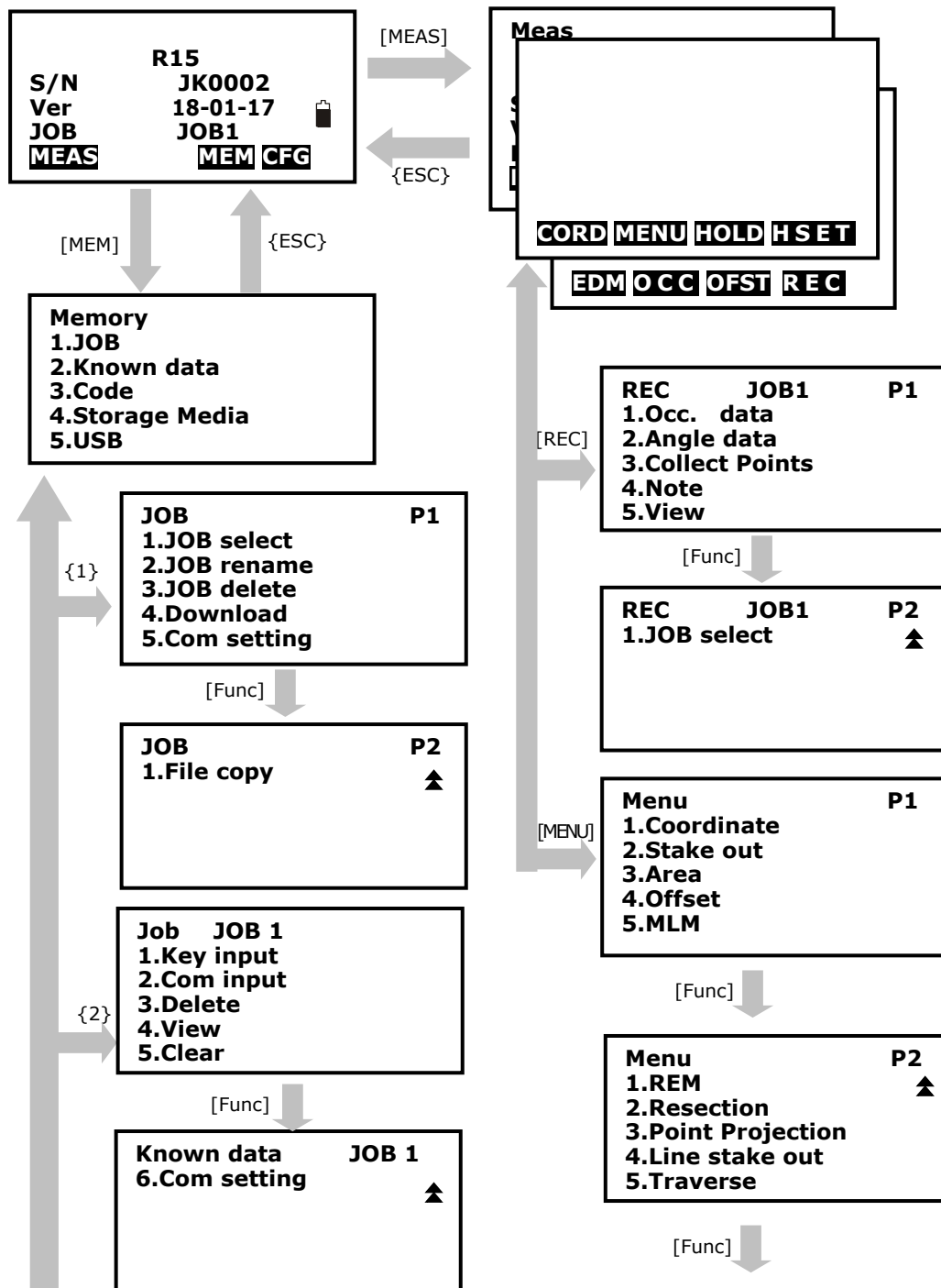

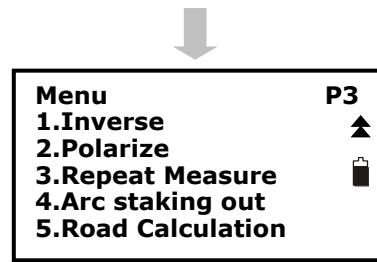
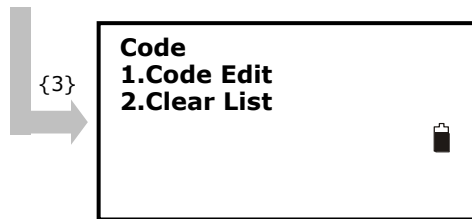

Configuration mode

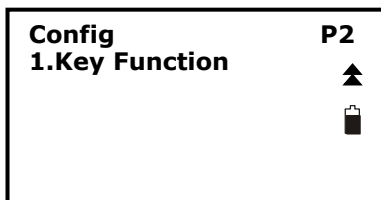
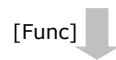
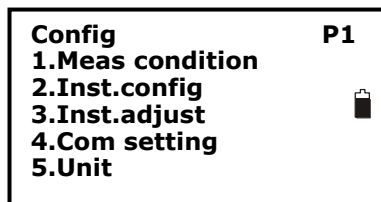
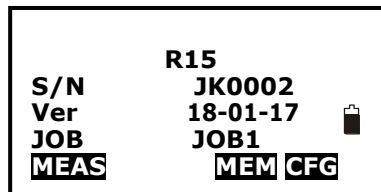

Setting mode (Press {★} directly)

```

Inst. Config      P1
1.Backlight      : YES
2.Laser          :NO
3.contrast       :9
4.Ret. Lev.      :0
EDM
  
```

```

Inst. Config      P2
1.Key Beep       : YES
2.Signal         :
EDM
  
```

4.3. How to input number and alphabet

```

PT# [REDACTED]
Inst.H: 1.200m A
NO: 100.000
EO: 100.000
ZO: 10.000
READ RES REC OK
  
```

Enter input code status, the cursor is blinking and ready to input. The note "A" at the top right corner shows the active input mode, you can press the {shift} key to switch between capital and minor letters and numbers.

```

PT# [REDACTED]
Inst.H: 1.200m 1
NO: 100.000
EO: 100.000
ZO: 10.000
READ RES REC OK
  
```

Input the code in turn and press the {ENT} key to save it or move to the following row. You can press {BS} key to delete your wrong input before the cursor.

4.4. How to select in research mode

```

Stn ST100
Stn ST200
Coor5
Dist 15
Ang 2
↑↓.P TOP LAST DEL
  
```

In the research display (on the left) you can find all the points saved in the active job. The data type (Stn= station point, Coor= point coordinates, Ang=point angles, etc.) are beside the point name. Use:

- [↑↓.P] to turn the next page;
- [TOP] to select the first point on the display;
- [LAST] to select the last point on the display;
- [SRCH] to input manually the point name to search.

NOTE: if more than one point exists in the current job, only the newer recorded data could be viewed.

5. Instrument settings

5.1. How to configure

Press {★} key on panel directly to enter any status and do some basic settings. Scroll all the options using ▲/▼ or {ENT} keys and. ◀/▶ keys to select the options. Press {Func} key to turn the page.

Inst. Config	P1
1.Backlight	: YES
2.Laser	: NO
3.contrast	: 9
4.Ret. Lev.	: 0
EDM	

Inst. Config	P2
1.key Beep	: YES
2.signal	:
	
EDM	

Backlight: to turn on or not the display illumination

Laser: to turn no/off laser beam for pointing target.

Contrast: to adjust LCD display contrast.

Ret. Lev. to adjust the telescope illumination on reticle. If the value is zero, the illumination is turned off.

Key beep: to turn on key beep or not, if you select NO, you will not hear the beep voice when press any key.

Signal: aim a target, then select the signal option and the instrument will beep, the EDM returned signal value will display simultaneously.

From the Inst. Config. menu press function F1[EDM] key to open the EDM setting menu.

5.2. EDM settings

Press {★} key on panel directly, then F1[EDM] key to define the electronic distance meter options. It is possible to arrive at the same page through the measuring menu: press F1[MEAS] in the status mode, press {Func} key to turn to page P3 and, then, press F1[EDM] to enter the EDM setting.

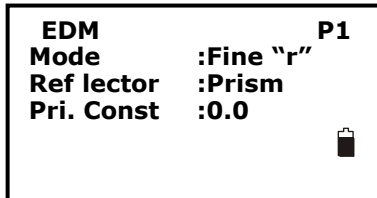

Change the settings if necessary. Press ▲/▼ keys to select the first three items and press ►/◀ keys to set the options.

Press {Func} key to turn to page 2.

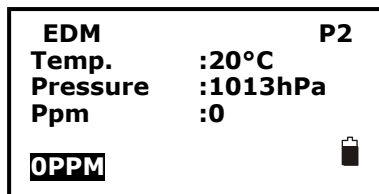

Press {ESC} key back to the previous mode.

Mode

The EDM Mode possesses five sorts of modes (Fine "r", Fine AVG,, Fine "s", Rapid "s", Tracking) which choice interfere with the accuracy of the measures. Worth noting that along with selected measuring mode the selections of prism types are different.

Fine "r"	The measuring is continuous and the number of measures is set by default.
Fine AVG	The measuring is continuous and the number of measures is chosen by the operator through the F3[↑] or F4[↓] keys.
Fine "s"	The distance is measured once and, for some EDM, a frequency is added to have an higher accuracy.
Rapid "s"	The distance is measured once. This measuring mode has the highest measuring speed but reduced accuracy.
Tracking	The distance is measured continually until F4[STOP] is pressed.

Reflector

With this option, it is possible to define the target type. Four types are available:

- Prism
- Lprism: to measure long range with prism
- Sheet
- No prism

Pri. Const: a prism constant can be entered with the following limit values: -99 mm to +99 mm.

Temp: air temperature can be set in the following ranges:

- -30~60°C
- -22~140°F

Pressure: air pressure can be set in the following ranges:

- 500~1400hPa
- 375~1050mmHg
- 14.8~41.3 inchHg
- 500~1400mbar
- 7.2~20.3Psi

ppm: atmospheric PPM can be defined in the range -499~499 (see Appendix I: Atmospheric correction formula and chart).

Press F1[**OPPM**] to set temperature, pressure and ppm as factory setting.

NOTE:

- Factory settings

Mode	Fine "r"
Reflector	Prism
Pri. const	0.0
Temp.	20°C 59°F
Pressure	1013hPa 760mmHg 29.9inchHg 1013mbar 14.7Psi
ppm	0

- Ppm value could be calculated by inputted temperature and pressure or input directly.
- This operation is also available in stake out mode.

5.3. How to set parameters

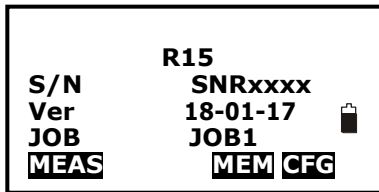

In the status mode, press F4[CFG] key to enter the config mode. It allows to set measure conditions, instrument configuration, communication parameters, units and key functions. Press {Func} key to turn the page.

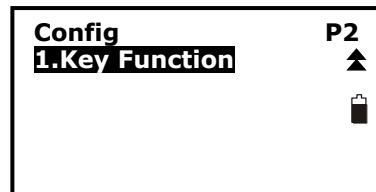
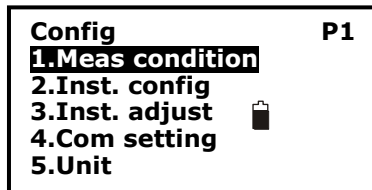

5.3.1. Measure condition setting

Select "1.Meas condition" to set measurement parameters. All items display on three pages. Press {Func} key to turn the page. Press ▲/▼ keys to select items and press ◀/▶ keys to set options. Press {ESC} key to go back to the previous mode.

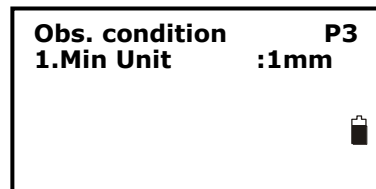
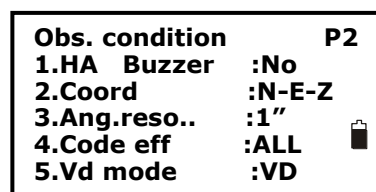
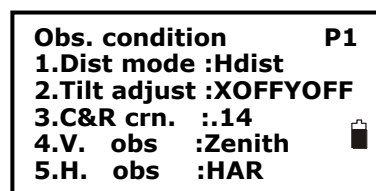

Dist mode: The distance measure mode can be set between:

- **Sdist** (SD) to measure the slope distance;
- **Hdist** (HD) to measure the horizontal distance;

- **Vdist** (VD) to measure the vertical distance.

It is possible to change the distance mode in the measure mode directly (see 6.2 Distance measurement).

Tilt mode: It allows to activate the compensator in one or two directions:

- **XONYON** the compensator is on in both the direction;
- **XONYOFF:** the compensator is on in the X direction only;
- **XOFFYOFF** the compensator is off in both the direction.

It is possible to select the tilt mode pressing the {BS} key on the keyboard directly.

C&R crn.: this coefficient takes into account the fact that measures can be affected to the refraction and the earth curvature (see Appendix II: Correction for refraction and earth curvature). Values can be chosen between .14, .20 and No.

V. obs: the zero of the vertical angle can be set with the following options:

- **VA:** the 0 is the horizontal axes on the face I
- **V90:** the 0 is the horizontal axes on both the faces of the instrument. The angle increases turning the objective upwards, decreases turning downwards. The maximum measurable angle is 100 gon (90°), which corresponds to the vertical axis.
- **Zenit:** the 0 is set when the objective is turned upwards in the vertical direction.

H. obs:

- **HAL:** the horizontal angle increases in the anticlockwise direction;
- **HAR:** the horizontal angle increases in the clockwise direction.

HA Buzzer: If this option is on, an acoustic signal sounds at right angles (0°, 90°, 180°, 270° or 0, 100, 200, 300 gon).

Example Sector Beep:

From 95.0 to 99.5 gon (or from 105.0 to 100.5 gon) a "Fast Beep" sounds while from 99.5 to 99.995 gon (or from 100.5 to 100.005 gon) a "Permanent beep" sounds.

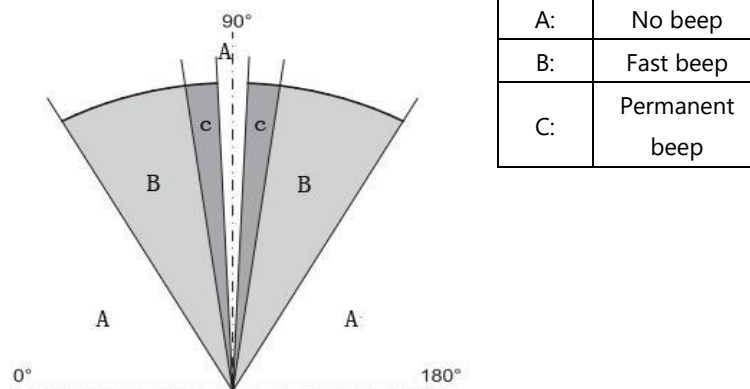

Coord.: It is possible to choose between two coordinate formats:

- **N-E-Z**

- **E-N-Z**

Ang. reso: The displayed minimum angle format can be selected in the following way:

- For gon: 0.001g/0.002g/0.0002g;
- For mil.: 0.005mil/0.02mil/0.05mil;
- For degree: 1"/5"/10";
- For dec. deg: 0.001°/0.0001°/0.0005°.

Code eff: The manual input code is available once (ONCE) or always (ALL).

Vd mode: the display mode of vertical distance can be chosen between:

- **VD:** if the vertical distance is measured from the instrument center;
- **GD** if the vertical distance is measured from the ground.

Min Unit: The displayed minimum distance format can be selected in the following way:

- For meter: 1 mm/0.1mm;
- For Us-ft.: 0.01ft/0.001ft;
- For Int-ft.: 0.01ft/0.001ft.

NOTE: Factory settings

Dist Mode	SD
Tilt Mode	XONYON
C&R crn	.14
V. obs	Zenith
H. obs	HAR
HA Buzzer	No
Coord	N-E-Z
Ang .reso	0.0002g 0.005mil 1" 0.001°
Code eff	ALL
Vd mode	VD
Min Unit	0.1mm 0.01ft

5.3.2. Instrument basic setting

In the config mode select "2.Inst. config" to set instrument basic parameters. Press ▲/▼ keys to select items and press ◀/▶ keys to set options. Press {ESC} key back to the previous mode.

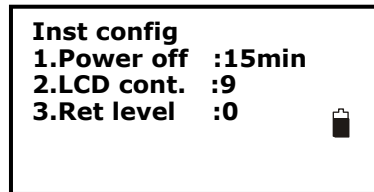

Power off: select the time after which the instrument would power off automatically to save battery if no operation in setting time. It is possible to choose between 5min/15min/30 min/No. selecting "No", the automatic power off is not set.

LCD cont: allows to modify the display contrast. Available values: 0~13.

Ret level: allows to modify the reticle illumination. Available values: 0~9.

NOTE: Factory settings

Power off	30 min
LCD cont	9
Ret level	7

5.3.3. Communication port setting

Please set communication parameters before connecting your computer.

In the config mode select "4.Com setting" to set the parameters of communication port.

NOTE: The values have to be set in the same way as on your computer.

Press ▲/▼ keys to select items and ◀/▶ to set options and press {Func} key to turn to page 2.

Press {ESC} key to go back to the previous mode.

Comms setting		P1
1.Baud rate	:	1200
2.Data bits	:	8bit
3.Parity	:	NO
4.Stop bit	:	1bit 
5.Check sum	:	No

Comms setting		P2
1.Xon/Xoff	:	No
		

- **Baud rate:** it is the communication velocity. Choose between 1200/2400/4800/9600/19200 /38400.
- **Data bits:** choose between 7/8.
- **Parity:** choose between YES/NO.
- **Stop bit:** choose between 1bit/2bit.
- **Check sum:** choose between YES/NO.
- **Xon/Xoff:** choose between YES/NO.

NOTE: Factory settings

Baud rate	1200
Data bits	8bit
Parity	No
Stop bit	1bit
Check sum	No
Xon/Xoff	No

5.3.4. Unit setting

In the Config mode select "5.Unit" to set unit. Press ▲/▼ keys to select items and ◀/▶ to set options. Press {ESC} key to go back to the previous mode.

Unit	
1.Temp.	:°C
2.Pressure	:hPa
3.Angle	:degree 
4.Dist	:meter

Temp.: Set the temperature between Celsius and Fahrenheit degree: °C/°F.

Pressure: Set the pressure between hPa/ mmHg / inchHg/mbar/psi.

Angle.: Set the angle measure unit between degree/gon/mil/dec.deg.

Dist.: Set the distance measure unit between meter/Us-ft/Int-ft.

NOTE: Factory settings

Temp.	°C
Pressure	hPa
Angle	degree
Dist	meter

5.3.5. Key function setting

In the second page of config mode select "1.Key function", here it is possible to manage and set the softkey arrangement in the measure mode. With "softkey" it is meant the commands and functions listed in the lower part of the display, which can be activated using the correspondent function keys (F1~F4).

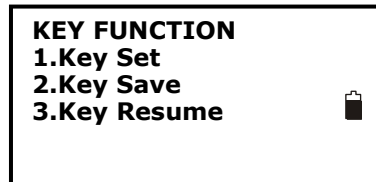

Key Set: the soft key's function at basic measurement mode can be changed.

Move the cursor to the key using ◀/▶, change the key's function according to your need by pressing ▲/▼ to select.

Press {F4} key to confirm the defined key.

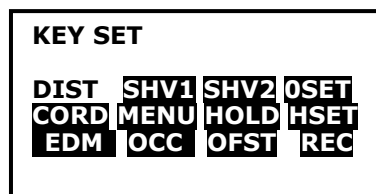

Following items can be defined:

Items	Descriptions
DIST	Start distance measure
SHV1	Display switching between SD/HA/VA, HD/HA/VA and VD/HA/VA
SHV2	Display switching between SD/HD/VD and SD/HA/VA
OSET	Set horizontal angle to 0
CORD	Enter coordinate measurement menu
MENU	Enter program menu
HOLD	Hold the horizontal angle
HSET	Set horizontal angle
EDM	Enter distance setting menu
OCC	Setting the station point
OFST	Enter offset measurement menu
REC	Enter points collection menu

RES	Enter resection program menu
REMS	Enter angle repeat measurement menu
MLM	Enter missing line measurement menu
S.O.	Enter stake out measurement menu
TILT	Display electronic level
REM	Enter remote elevation measurement menu
HARL	Horizontal angle display switching between HR and HL
ZA/%	Vertical angle display switching grade and zenith
OUT	Output the current measurement data via RS-232C port
AREA	Enter area measurement menu
ROAD	Enter road measurement menu
IHT	Enter instrument height setting menu
LSO.	Enter line stake out measurement menu
PROJ	Enter point projection measurement menu

Key Save: Select the User Define in which you want to save the current key.

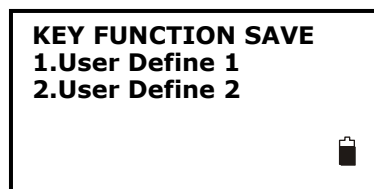

Key Resume: Select one of the item in which you want to resume the current key setting

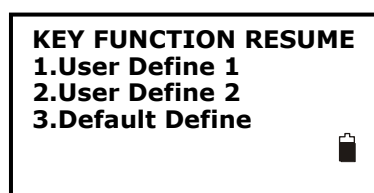

6. Measurement

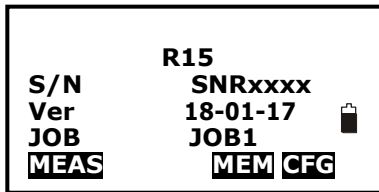

In the status mode, press F1[MEAS] key to enter the measure mode.

6.1. Angle measurement

6.1.1. Measure a horizontal angle of two points

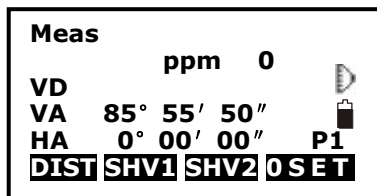
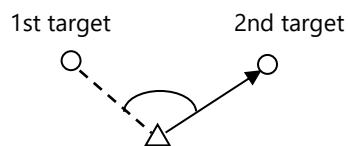

Sight the 1st target.

Press F4: [0SET] twice to set the 1st target as 0° at P1 in the measurement mode.

Press [SHV1] or [SHV2] to change display status firstly if in distance mode.

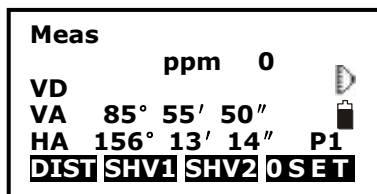

Sight the 2nd target. The displayed value is the included angle between two points.

6.1.2. Set the horizontal angle to a required value

```

Meas
                ppm  0
VD
VA 302.5432gon
HA 0.0000gon  P2
CORD MENU HOLD HSET
  
```

Take your instrument sight the 1st target.

Press F4: [HSET] at the second page (P2) in the measurement mode.

```

Set H Angle
1. Azimuth
2. Back sight
  
```

Select the first item "1. Azimuth".

```

Azimuth -399.9998
Tgt.H      0.000m
PT#
Observe point!
                OK
  
```

Input the required value in Azimuth field, then press {ENT} to save the value and it displays as the horizontal angle. Range and format of the input value:

- gon: 0~399.9999
- degree: 0~359.5959
- mil: 0~6399.990

```

Meas
                ppm  0
VD
VA 302.5432gon
HA 399.9998gon  P2
CORD MENU HOLD HSET
  
```

In the measure mode, HA is the inputted azimuth value.

NOTE: Pressing F3[HOLD] it performs the same function as above. The horizontal angle is in hold status when [HOLD] is flashing, press [HOLD] again to release the hold status. Turning the instrument, the HA value changes value.

6.2 Distance measurement

Please set the following items before distance measurement:

- Measurement condition (See 5.3.1. Measure condition setting)
- EDM (See 5.2. EDM settings)

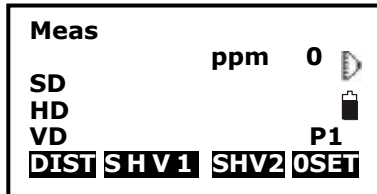

Aim at the target, press F3[SHV2], the display mode of basic measurement will change to SD/HD/VD (slope distance, horizontal distance and vertical distance) mode, and then press F1[DIST] to start measuring distance.

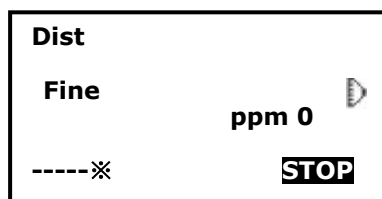

The symbol "*" moves continually when measuring distance. Distance measuring mode, prism const and ppm value are also presented.

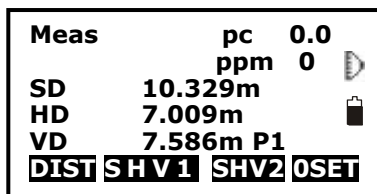

Press F4[STOP] to finish measurement. The "SD", "HD", and "VD" will display as shown left.

NOTE:

- Make sure that the target setting in the instrument matches the type of target used.
- If the objective lens is dirty, it will affect the accurate of measured results. Dust it off with your special brush and wipe it with your special cloth (in your carrying case) before putting away.
- If an object with a high reflective factor (metal, white surface) exists between the instrument and the target when measuring, the accuracy of the measured results will be affected.
- An angle is also able to be measured when distance measurement.
- Measurement will automatically stop after a single measurement if the EDM mode is single (Fine "S" / Rapid "S").
- If the distance measurement mode is average "Fine AVG", the measured distances are displayed as "-1", "-2", "-3", ..., "-9" in turn, and the average value will display behind "-A" once the selected time's measurement has been finished.

7. Pre-survey operations

7.1. Set a job

Jobs contain measurement data of different types (e.g. fixed points, measurements, codes, stations, etc. ...). All recorded data is stored in this job. Besides, if no job has been defined and an application have been started, measures are automatically saved in the last selected job. To set the job, refer to 9.6. Job select.

7.2. Set the station

Each coordinate computation relates to the set station. At least plan coordinates (E, N) are required for the station; the station height can be entered if required. The coordinates can be entered either manually or read from the internal memory.

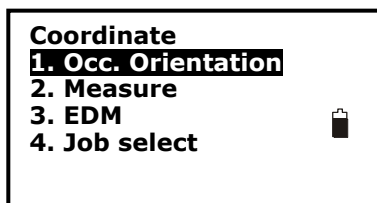

Press F1[MEAS] key to enter the measure mode. Then, select [MENU] softkey and open the program you want to use Select "1.Occ. Orientation".

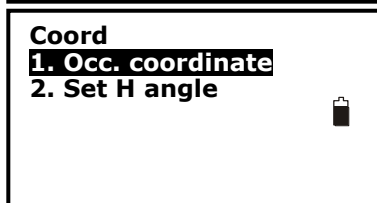

Select "1.Occ. coordinate"

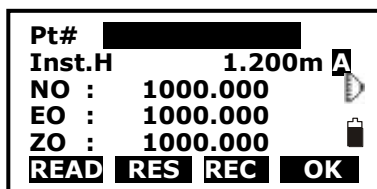

It is required to input the occupied station coordinates. It is possible to:

- Edit them in the fields of the screen and press F3[REC] key to memorize or F4[OK] to proceed without saving.



You can input the following items by hand: PT# (point ID-max 14 characters), Inst.H (instrument height- range: -9999.999~9999.999), NO-E0-Z0 (point coordinates), code (max 14 characters), user, weather (Fine, Cloudy, Flurry, Rain, Snow), wind (Calm, Gentle, Light, Strong, Gust), temperature, pressure, and ppm (range: -499 ~ 499 ppm). Press ▲/▼ keys to select item or press [FUNC] to turn page.

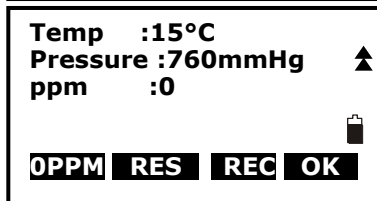

In the third page, press F1[OPPM] to set ppm value to 0.

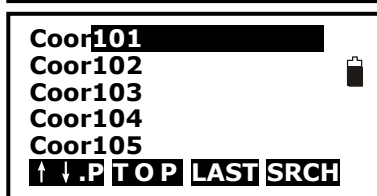

- Search a saved point in the memory using the F1[READ] key. In the search mode (figure on the left), use:
 - [↑↓.P] to scroll the page;
 - [TOP] to select the first point on the screen;

- [LAST] to select the last point on the screen;
- [SRCH] to input manually the point name.

NOTE: If more than two points with the same point name exist in the current JOB, the instrument finds the first recorded data only.

Once the point is selected, press the {ENT} key. Coordinates are resumed on the screen, it is possible modify the valued without affecting the original data. Press F4[OK] key to save.

```

PT# 101
Inst.H: 1.200m
NO: 100.000
EO: 100.000
ZO: 10.000
READ RES REC OK
  
```

```

Resection
1.NEZ
2.Elevation
  
```

- Determine the station coordinates, knowing other surrounding points, through the resection program (also known as free station). Press F3[REC] key and refer to 8.7. Resection for the instructions.

Once having inputted the coordinates, it is necessary define the orientation. Choose between:

```

Set H angle
1.Azimuth
2.Back sight
  
```

- 1.Azimuth if you desire to define the backsight point manually;
- 2.Back sight if you desire to edit or search from memory the backsight point coordinates.

```

Azimuth 0.000gon
Tgt.H 1.000m
Pt# 102
Osserva punto!
MEAS REC OK
  
```

For the former, insert the backsight point azimuth, the target height and the name. Aim at the backsight point and press F1[MEAS] key.

```

Azimuth 0.000gon
Tgt.H 1.000m
Pt# 102
HD 1.523m
REC OK
  
```

Press the F3[REC] key to save and set the station. If you press F4[OK] key, the station is set but the backsight point is not recorded.

```

PT# 102
Tgt.H: 1.200m
NBS: 112.068
EBS: 100.000
ZBS: 11.052
READ OK
  
```

For the latter, it is required to insert the backsight point coordinates. It is possible to:

- Edit them manually in the available field of the screen and press F3[REC] key;
- Search a point in the memory pressing the F1[READ] key. In the research window press:
 - [↑↓.P] to scroll the pages;
 - [TOP] to select the first point on the screen;
 - [LAST] to select the last point on the screen;
 - [SRCH] to input manually the point name.

```

Coor101
Coor102
Coor103
Coor104
Coor105
↑↓.P TOP LAST SRCH
  
```

NOTE: If more than two points with the same point name exist in the current JOB, the instrument finds the first recorded data only.

Once the point is selected, press the {ENT} key. Coordinates are resumed on the screen, it is possible modify the valued without affecting the original data. Press F4[OK] key to save.

PT#	102
Inst.H:	1.200m
NBS:	112.068
EBS:	100.000
ZBS:	11.052
READ	OK

If the same coordinates as the occupied point by the station are inserted, the alert message "Same coord." appears. Insert a different point.

Aim at the backsight point and press the F1[MEAS] key to measure the distance.

Azimuth	120.036gon
Tgt.H	1.000m
Pt# 102	
MEAS	REC
	OK

Press the F3[REC] key to save and set the orientation. If you press F4[OK] key, the station is set but the backsight point is not recorded.

Azimuth	120.036gon
Tgt.H	1.000m
Pt# 102	
HD	1.553m
	REC
	OK

8. Survey programs

Predefined programs that cover a wide spectrum of surveying duties and facilitate daily work in the field are available. Press the F1[MEAS] key to enter the measure mode. Then, select the [MENU] softkey.

Menu	P1
1.Coordinate	
2.Stake out	
3.Area	
4.Offset	
5.MLM	

Select the row with the program you desire to use, through the ▲/▼ or {ENT} keys. Press {Func} key to scroll the following page.

In many programs, it is required to set the station: refer to 7.2. Set the station for the instructions.

8.1. Coordinate measurement

It is possible to find target coordinates inputting the occupied coordinate, instrument height, target height, back sight coordinate (or azimuth angle) and azimuth before coordinate measurement.

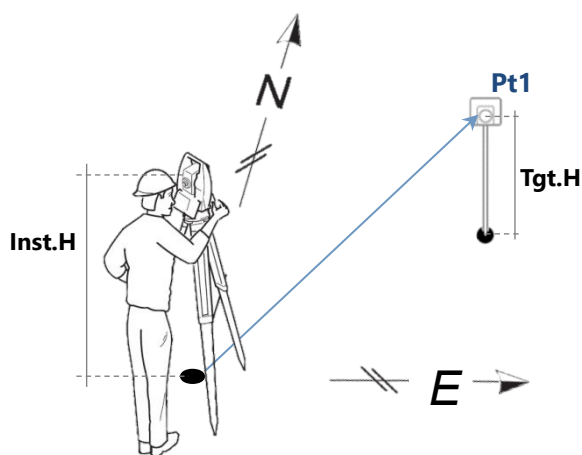

Pt1: primo bersaglio (punto misurato)
Tgt. H: altezza del bersaglio
Inst.H: altezza strumentale

The formulas used to calculate are:

$$N1 = N0 + S \times \sin Z \times \cos Az$$

$$E1 = E0 + S \times \sin Z \times \sin Az$$

$$Z1 = Z0 + S \times \cos Z + IH - TH$$

Where:

- N0- E0- Z0:* occupied point coordinates
- S:* Slope distance
- Z:* Zenith angle
- Az:* Azimuth angle
- IH:* Instrument height
- TH:* Target height

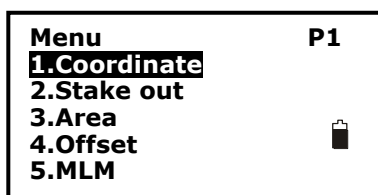
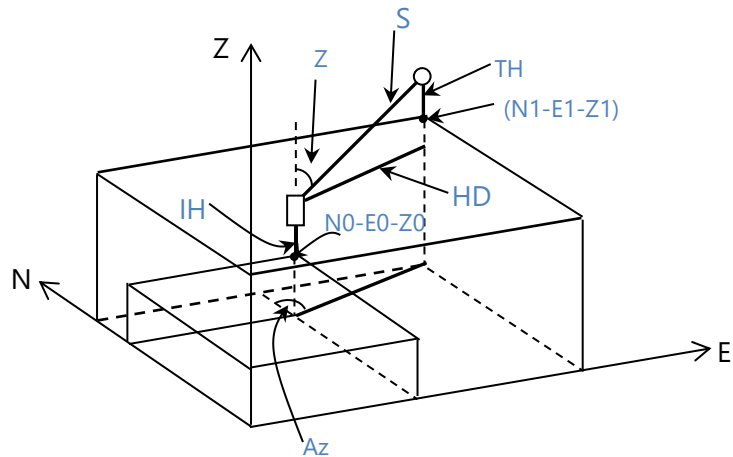

Press [MENU] softkeys in the measure mode.
Select "1. Coordinate".

As alternative, it is possible to enter the same page pressing the [CORD] softkey in the measure mode page.

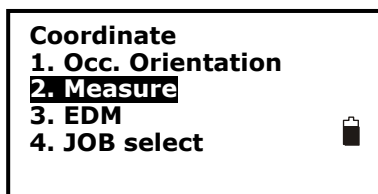

After having set the station (refer to 7.2. Set the station for instructions), aim at the target point and select "2. Measure" to start.

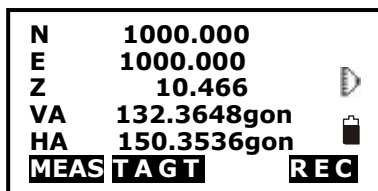

The target coordinate values are displayed.

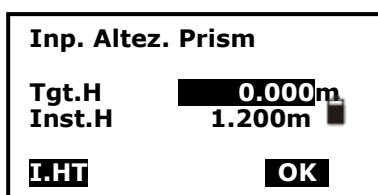

Press F2[TAGT] to input the target (Tgt.H) and instrument (Inst.H) heights.
Press F4[OK] key to turn the previous page.

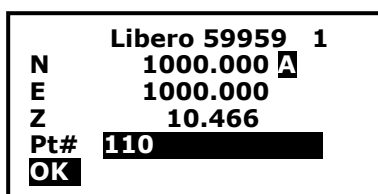

To save press F4[REC] key.
Insert the point name (Pt#) and, eventually, the target height and the code in the second page (use {Func} key to scroll). Press F1[OK] key to store the point.

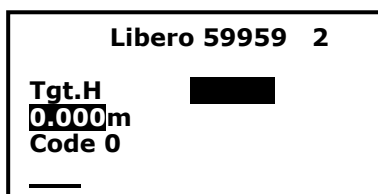

	Libero 59959 1
N	1000.000 
E	1000.000
Z	10.466
Pt#	110
OK	

If the inserted point name already exists, it is required if overwrite or not.

Press:

- F1[ADD] to create a new point with the same name;
- F3[NO] to change the point name;
- F4[YES] to overwrite.

Collimare il bersaglio successivo e premere F1[MEAS] per iniziare una nuova misura.

8.2. Stake out measurement

Stake out measurement is used to stake out the required point. The difference between the previously inputted data to the instrument (the stake out data) and the measured value can be displayed by measuring the horizontal angle, distance or coordinates of the sighted point.

The horizontal angle difference and distance difference are calculated and displayed using the following formulas:

Horizontal angle difference

$dHA = \text{Horizontal angle of stake out data} - \text{measured horizontal angle}$

Distance difference

$SD = \text{measured slope distance} - \text{slope distance of stake out data}$

$HD = \text{measured horizontal distance} - \text{horizontal distance of stake out data}$

$VD = \text{measured height difference} - \text{height difference of stake out data}$

Stake out data can be input in various modes: SD, HD, VD, coordinates and REM measurement.

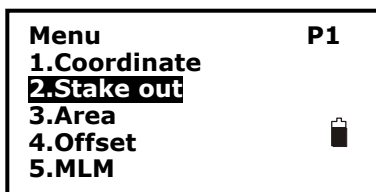

Press [MENU] softkeys in the measure mode.
Select "2. Stake out".

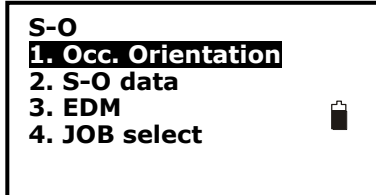

After having set the station (refer to 7.2. Set the station), automatically, it returns the stake out menu. Before inserting data for the tracking, it is possible to modify the EDM settings, selecting "3.EDM". It is suggested to activate "Tracking" as mode, in order to have many measures in sequence. For more details, refer to 5.2. EDM settings.

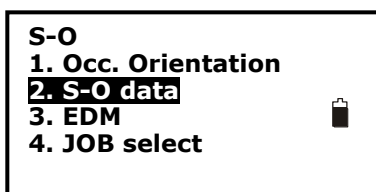

Select "2. S-O data".



Three staking out modes are available.

8.2.1. Distance stake out

The point to be found based on the horizontal angle from the reference direction and the distance from the instrument station.

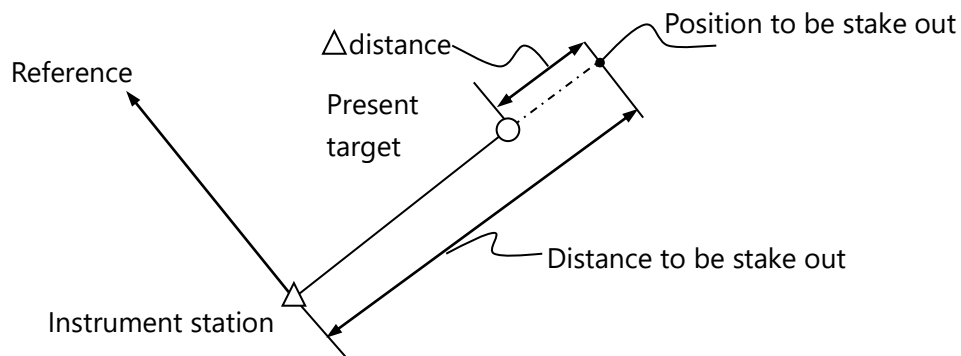

For the distance stake out, select "2. Angle & Dist".

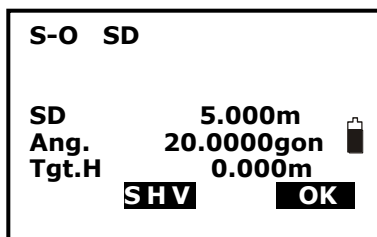

Press F2[SHV] to shift the distance type to stake out. Choose between slope distance (SD), horizontal (HD), vertical (VD). Input the following items:

- SD/HD/VD: distances from the instrument station to the position to be stake out;
- Ang.: included angle between the direction of the reference and the point to be stake out;
- Tgt.H: target height.

Press F4[OK] to set the input values.

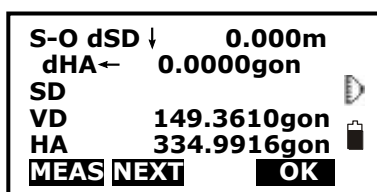

The difference of measured and stake out values "S-O dSD" are displayed. Move the prism forward and backward until "S-O dSD" is 0m.

Horizontally rotate the instrument until "dHA" is near 0 and set the target on the sight line.

Press F1[MEAS] to start distance measurement.

- ←: Move the prism left
- : Move the prism right
- ↓: Move the prism forward
- ↑: Move the prism backward

Press F4[OK] back to stake out mode.



8.2.2. Coordinates stake out measurement

After setting coordinates for the point to be stake out, the instrument calculates the stake out HA and HD. By selecting the HA and then the HD stake out functions, the required coordinate location can be stake out.

To get the Z coordinate, attach the target to a pole etc., with the same target height.

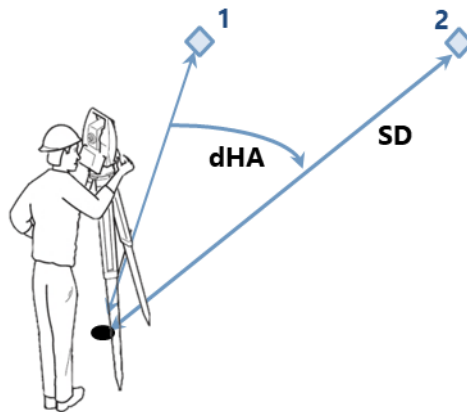

- 1:** Current point
- 2:** Point to stake out
- dHA:** Angle offset
- HD:** Horizontal distance offset



For coordinate stake out, select "3.Coord".

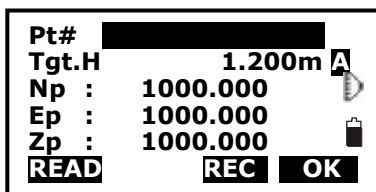

Input the coordinates of the stake out point and press F3[REC] to memorize. As alternative, it is possible to select a point from memory through the F1[READ] key: once you have selected the point, press {ENT} and F4[OK]. In both the case, insert target height (Tgt.H).

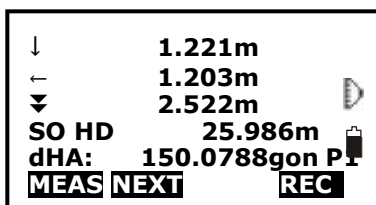

Press F1[MEAS] begin coordinate stake out measurement.

- ←: Rotate the instrument clockwise
- : Rotate the instrument anticlockwise
- ↑: Move the telescope upwards
- ↓: Move the telescope downwards
- ↖: Move nearer the prism
- ↗: Move further the prism

Press {ESC} key to go back to the previous menu.

8.2.3. REM stake out measurement

Perform this operation to find a point where a target cannot be directly installed, see 8.6. REM.

Set a target directly below or directly above the point to be found, then use a measuring tape etc. to measure the target height (height from the surveying point to the target).



For the remote height measure stake out, select "1. Height".

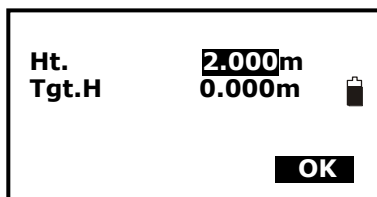

Input height from the surveying point to the position to be stake out. Then press F4[OK] to set the data.

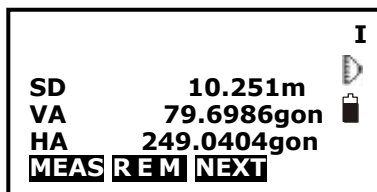

Press F2[REM] to begin REM stake out measurement.

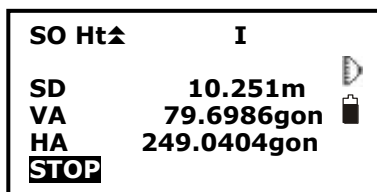

Move telescope to find the point to be stake out.

- ▼ : Move the telescope near the nadir
- ▲ : Move the telescope near the zenith.

Press F1[STOP] to end the measure or press {ESC} key back to stake out mode.

8.3. Area

Calculate an area shaped with several points. The coordinate data of the points could be either measured or input by hand.



Input:

Coordinates: P1 (N1, E1)
 P2 (N2, E2)
 P3 (N3, E3)
 ...

Output:

Area: S

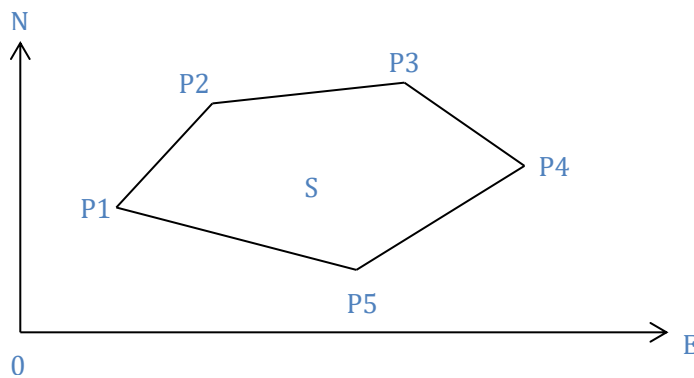

NOTE:

- The number of points: 3 ~ 30.
- Make sure these points must be measured or listed clockwise or anticlockwise, or mistake will result.



Press [MENU] softkeys in the measure mode.
 Select "3. Area".

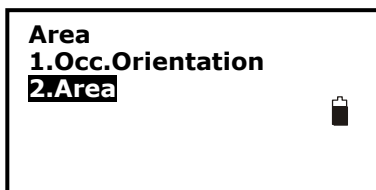

After having set the station (refer to 7.2. Set the station), in the programs menu, select "2.Area".



On the display, you can see the points progression to insert to evaluate the area. Press:

- F1[READ] to select points from memory
- F4[MEAS] to measure points

```

coor1
coor2
coor3
coor4
coor5
↑↓.P TOP LAST SRCH

```

For the former, select the point and press {ENT} key.

```

N          10.000 I
E          5.000
Z          53.493
VA        152.6296gon
HA        62.1314gon
OK          MEAS

```

For the latter, press F4[MEAS] directly.

Press F4[MEAS] to re-measure distance or press F1[OK], the measured data is set as "Pt-01".

```

01:Pt_01
02:Pt_02
03:Pt_03
04:Pt_04
05:
CALC          MEAS

```

Repeat the previous steps till all points are measured one by one. Make sure measure them clockwise or anticlockwise. Press F2[CALC] and the calculated area will display.

```

Area Calculation
Pt: 4
PArea      m2
               ha
OK

```

Press F4[OK] back to menu mode

8.4. Offset measurement

Offset measurement are performed in order to find a point where a target cannot be installed directly or to find the distance and angle to a point which cannot be sighted.

It is possible to find the distance and angle to a point you wish to measure (target point) by installing the target at a location (offset point) a little distance from the target point and measuring the distance and angle from the surveying point to the offset point.

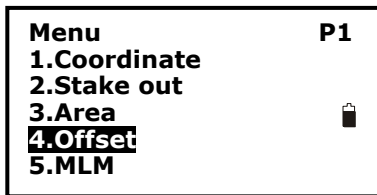

Press [MENU] softkeys in the measure mode.

Select "4.Offset". It is possible to enter the same page pressing the [OFST] softkey in the measure mode page.

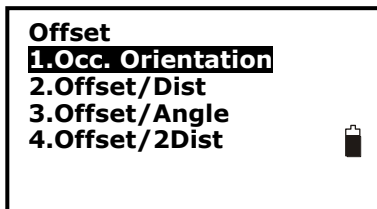

Select "1. Occ. orientation" to input the instrument occupied data, see 7.1.1. Input the occupied point data.

The target point could be found in the following three ways.

8.4.1. Single-distance offset measurement

Finding a point by entering the horizontal distance from the target point to the offset point.

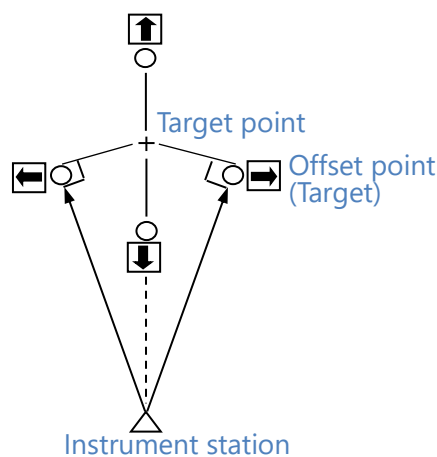

When the offset point is positioned to the left or right of the target point, make sure the angle formed by lines connecting the offset point to the target point and to the instrument station is almost 90°.

When the offset point is positioned in front of or behind the target point, install the offset point on a line linking the instrument station with the target point.

Set the offset point close to the target point and measure the distance between them, then set up a prism on the offset point.

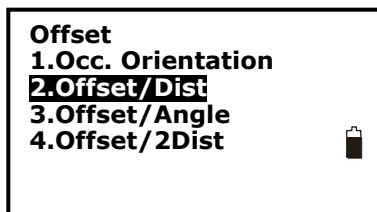

Set the station, select "2.Offset/Dist".

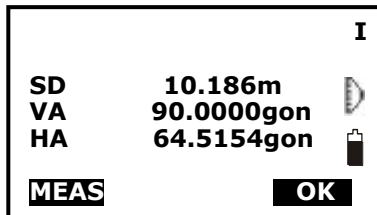

Aim the point and press F1[MEAS] to measure. Press F4[OK] to confirm or F1[MEAS] to repeat.

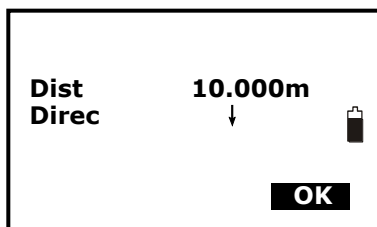

Input:

Dist: horizontal distance from the target point to the offset point.

Direc: direction of the offset point.

←: on the left of the target point

→: on the right of the target point

↓: in front of the target point

↑: at back of the target point

Press F4[OK] to calculate and display the distance and angle of the target point.

Press F1[REC] to save;

Press F2[NEZ] to display NEZ coordinate;

Press F3[NO] back to previous step;

Press F4[YES] back to offset mode.

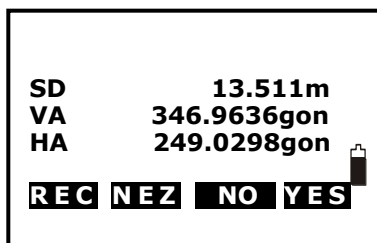

8.4.2. Angle offset measurement

Sighting the direction of the target point to find it from the included angle. Set offset points for the target point on the right or left sides of and as close as possible to the target point and measure the distance to the offset points and the horizontal angle of the target point.

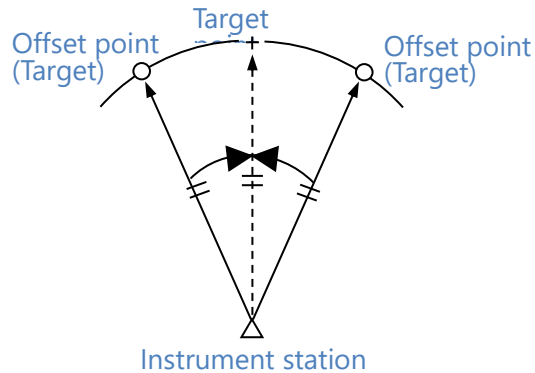

Set the offset points close to the target point (making sure the distance from the instrument station to the target point and distance to the offset point are the same, the height of the offset points and the target point are the same), then use the offset points as the target.

Aim at the offset point and press F1[MEAS] to measure the distance at P1 in measure mode.



Select "3. Offset/Angle".

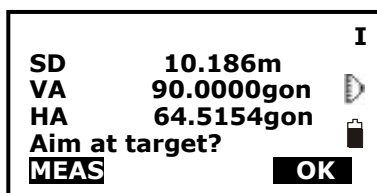

Accurately sight offset point and press F1[MEAS]. Then, sight the target direction and press F4[OK].

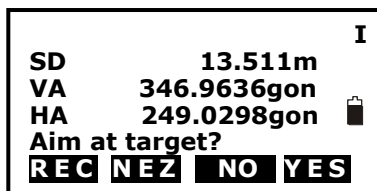

After finishing measurement:

Press F1[REC] to save;

Press F2[NEZ] to display NEZ coordinate;

Press F3[NO] back to previous step;

Press F4[YES] back to offset mode.

8.4.3. Dual-distance offset measurement

By measuring the distance between the target point and the two offset points. Set two offset points (1st target and 2nd target) on a straight line from the target point, measure the 1st and 2nd target, then input the distance between the 2nd target and the target point to find the target point.

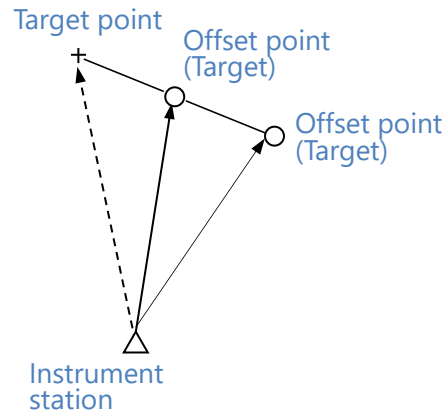

Set two offset points (1st target, 2nd target) on a straight line from the target point and use the offset points as target.



Set the station, select "4. Offset/2Dist".

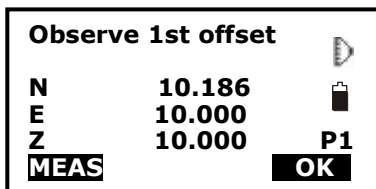

Aim at the 1st target and press F1[MEAS] and measured data will display. Press F4[OK] to accept this value.

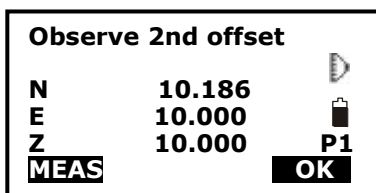

Sight the 2nd target, press F1[MEAS] and measured data will display, press F4[OK] to accept this value.

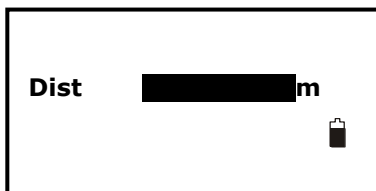

Input the distance from 2nd point to the target point and press {ENT} key, the angle and distance of the target point are displayed.

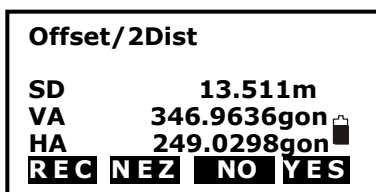

After finishing measurement:

- Press F1[REC] to save;
- Press F2[NEZ] to display NEZ coordinate;
- Press F3[NO] back to previous step;
- Press F4[YES] back to offset mode.

8.5. MLM

MLM is used to directly measure slope distance, horizontal distance and the height difference from one base point to other points without moving the instrument.

NOTE:

- The last measured data could be set as the base point for the next starting operation.
- The height difference between one point and the base point could be displayed as grade mode.

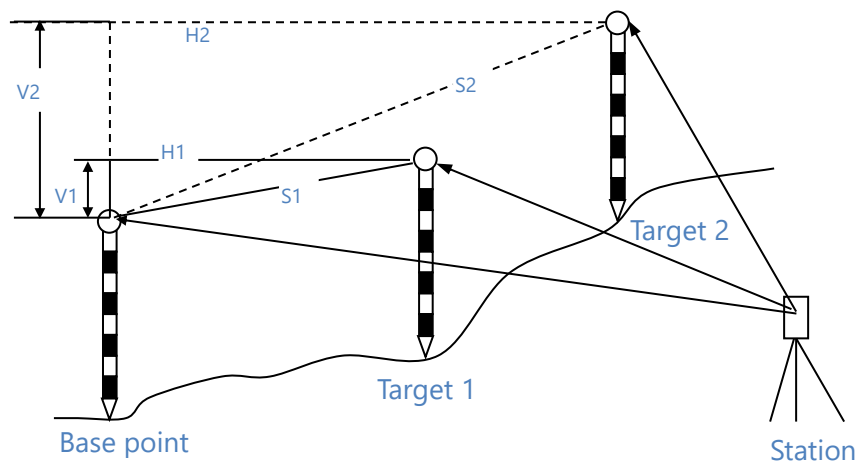

8.5.1. Measuring distance between two or more points

Menu	P1
1.Coordinate	
2.Stakeout	
3.Area	
4.Offset	
5.MLM	

Press [MENU] softkeys in the measure mode.

Select "5. MLM".

	I
SD	4.886m
HD	4.497m
VD	1.911m
MLM	MOVE MEAS

Aim at the start point P1, then press F4[MEAS] and the measured data will display.

	I
S/%	-10.11%
SD	2.041m
HD	2.029m
VD	-0.218m
MLM	MOVE MEAS

Aim at the target point P2 and press F1[MLM] to begin measuring: SD, HD, VD distances and gradient (S/%) between two points are displayed.

Aim at the next point P3 and press F1[MLM] to begin measuring. Repeat this operation to measure other target points.

Press F2[MOVE], the last target measured becomes the new starting

position to perform MLM of next target.
 Press F4[MEAS] to re-measure the starting position.
 Press {ESC} key to go back to menu mode.

8.5.2. Change the starting point

The previous measured data could be set as the base point for the next operation.

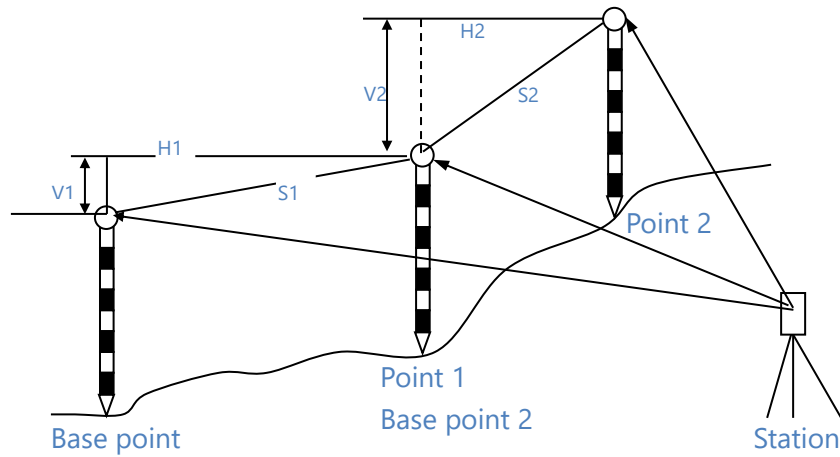

Move base point?	
SD	-0.001m
VA	368.3854gon
HA	243.4068gon
<input type="checkbox"/> NO <input checked="" type="checkbox"/> YES	

Measure the start point P1 and the first target P2 following above steps.

After measuring the two points, press F2[MOVE], and press F4[YES] to set the last measured point as new starting point, or press F3[NO] to give up.

8.6. REM

REM is a function used to measure the coordinate and height to a point where a target cannot be directly installed such as power lines, overhead cables or bridges, etc. Set a target directly under or directly over the object.

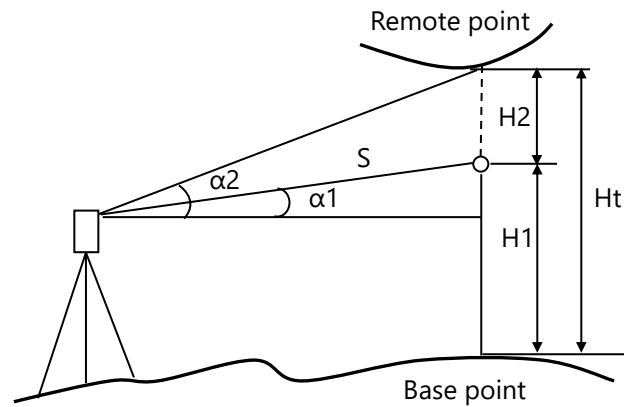

Here is the equation used to calculate the height with respect to the ground, presented in above figure:

$$Ht = H1 + S \cos \alpha 1 \tan \alpha 2 - S \sin \alpha 1$$



In the second page of programs menu, select "1.REM"

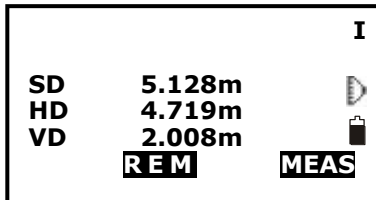

Aim at the prism accurately and press F4[MEAS] to measure distance. Measured data are displayed. Press F4[MEAS] to re-measure.

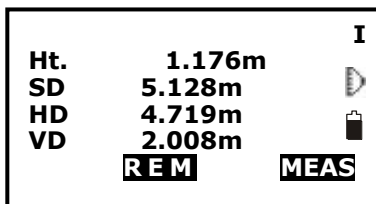

Aim at the remote point accurately and press F2[REM]. The height from ground (Ht) to the target is displayed. Press F4[MEAS] to repeat and press {ESC} key to go back to menu mode.

8.7. Resection

Resection program is used to determine the coordinates of an instrument station (unknown) by measuring several known points. Coordinate data in memory could be read.

Input

Coordinates of known points: N_p, E_p, Z_p

Measured HA: H_i

Measured VA: V_i

Measured distance: D_i

Output

Coordinate of occupied data: X_o, Y_o, Z_o

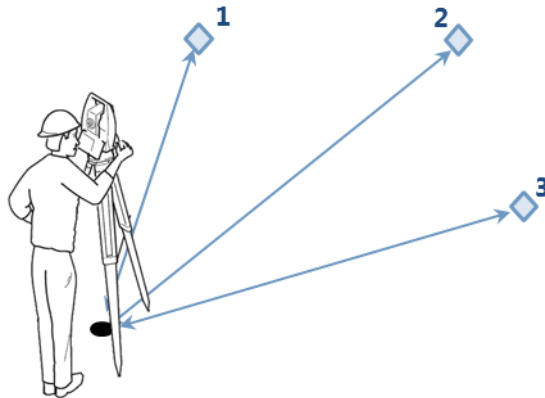

NOTE:

- All N, E, Z value or only Z value of the occupied point is calculated by measuring known points.
- Coordinate resection measurement overwrite the N, E, Z data of the instrument occupied point, while elevation resection measurement overwrite Z data only. Perform resection measurement, see 7.7.1. Coordinate resection and 7.7.2. Elevation resection.
- Inputted known coordinate data and calculated data could be recorded in the current JOB.

8.7.1. Coordinate Resection

Between 2 and 5 known points can be measured by distance measurement and angle measurement.

```

Menu                               P2
1.REM
2. Resection
3. Point Projection
4. Line stake out
5. Traverse
    
```

In the second page of programs menu, select "2.Resection"

```

Resection
1.NEZ
2.Elevation
    
```

Select "1.NEZ" and input known point data.

Pt#: point name

Tgt.H: target height

Np-Ep-Zp: point coordinate

```

Pt#
Tgt.H                               mA
Np:
Ep:
Zp:
READ REC NEXT MEAS
    
```

Press F1[READ] to read existed coordinate data. After inputting the data of the first known point, press F3[NEXT] to input the second point data.

After all known points data have been set, press F4[MEAS].

```

Resection  No.1PT
N
E
Z
Pt#
DIST ANG
    
```

Sight the first known point and press F1[DIST] to begin measurement. If known points number is more than two, F2[ANG] will display, you can confirm the known point by angle measurement.

```

Resection  No.1Pt  I
SD          10.188m
VA          189.9284gon
HA          47.2432gon
Tgt.H      [ ]m
          NO YES
    
```

Insert target height (**Tgt.H**).

Press F4[YES] to use the measured data of the first known point.

Press F3[NO] to re-measure this point.

```

Resection  No.2Pt  I
SD          10.188m
VA          189.9284gon
HA          47.2432gon
Tgt.H      [ ]m
CALC          NO YES
    
```

Repeat previous procedures for other points.

When the minimum quantity of measured data required for the calculation is present, [CALC] will be displayed.

Press F1[CALC] to calculate. Instrument occupied coordinate and standard deviation are displayed.

Press F3[NO] to re-measure the point.

```

N
E
Z
dN
dE
NEXT DISP REC OK
    
```

Press F1[NEXT] to add other known points.

Press F2[DISP] to view the tolerance of measured known points

Press F3[REC] to record the calculated result.

Press F4[OK] to finish coordinate resection.

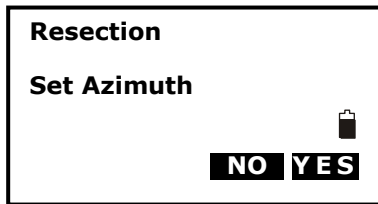

The instrument occupied coordinate setting is finished.
In this <Set Azimuth> screen, aim the first point then press F4[YES] to set the first known point as back sight point and azimuth, press F3[NO] to back to measure mode.

8.7.2. Elevation Resection

Only Z (elevation) of an instrument station is determined by this measurement. Between 1 and 5 known points can be measured by distance measurement only.



In the second page of programs menu, select "2.Resection"

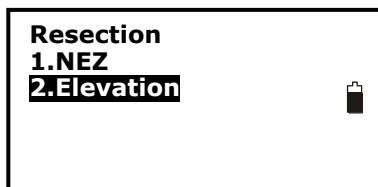

Select "2. Elevation" and input the known point.

Pt#: point name

Tgt.H: target height

Z: point elevation

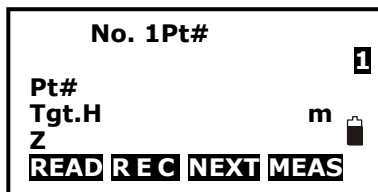

Press F1[READ] to read existed coordinate data.

After setting the elevation for the first known point, press F3[NEXT] to set the second point data.

After all known points data have been set, press F4[MEAS].

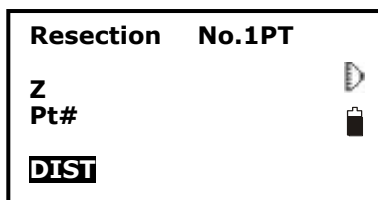

Sight the first known point and press F1[DIST] to begin measurement. The measured data are displayed.

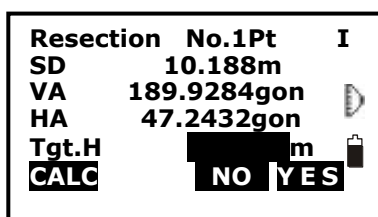

Insert target height (**Tgt.H**).

Press F4[YES] to use the measured data of the first known point data.

Press F3[NO] to re-measure the point.

After finishing two measurements, [CALC] will be displayed. Press F1[CALC] to calculate. Instrument occupied elevation and standard deviation are displayed.

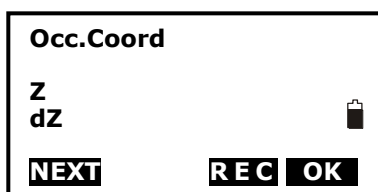

Press F1[NEXT] to add other known points.

Press F3[REC] to record the calculated result.

Press F4[OK] to finish elevation resection.

Only Z (elevation) of the instrument occupied coordinate is set. N and E values would not be overwritten.

8.7.3. Resection Calculation Process

The N, E coordinates are found by angle and distance measurement equations, and the instrument occupied coordinates are found using the least squares method. The Z coordinate is found by treating the average value as the instrument occupied coordinate.

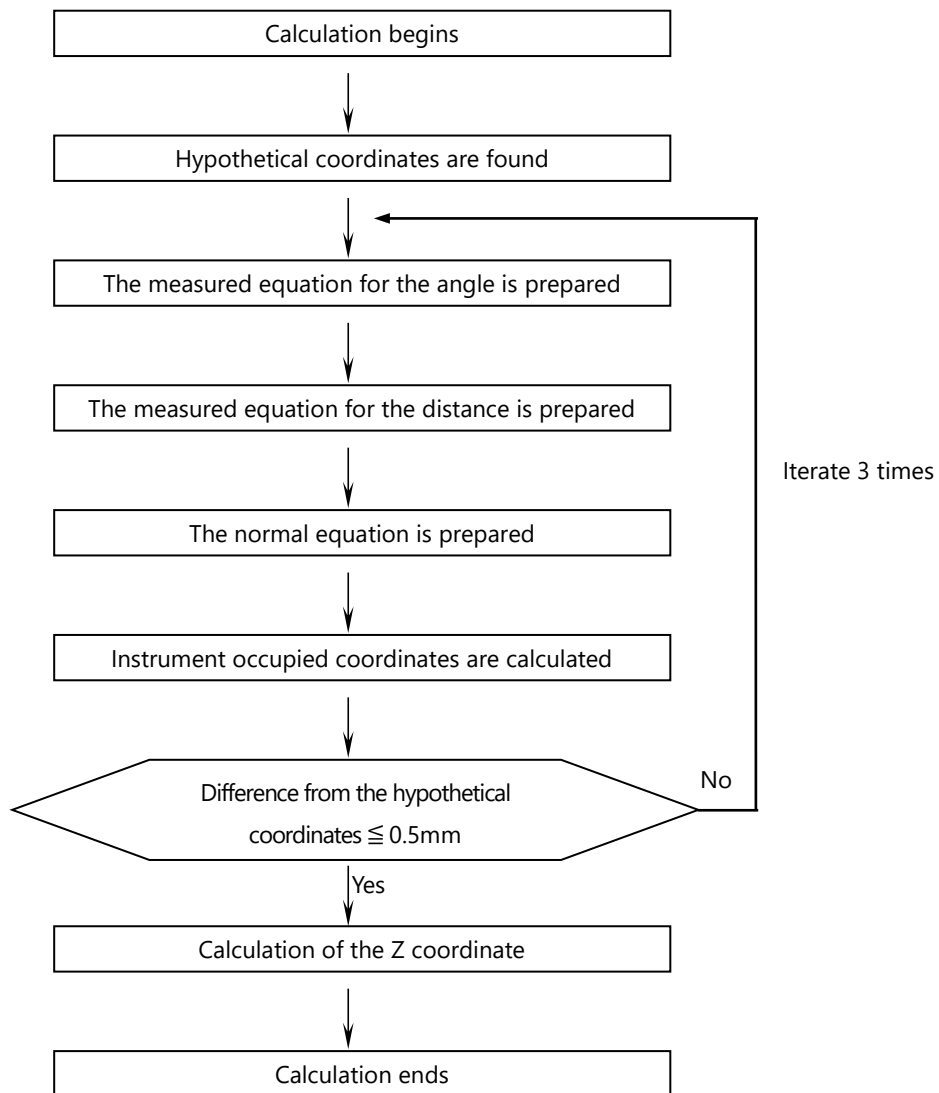

8.7.4. Precautions When Performing Resection

An arrangement such as shown below is desirable.

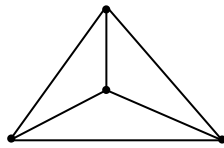

△▲ : unknown point

○● : known point

In some cases, it is impossible to calculate the coordinates of occupied point if the unknown point and three or more known points are arranged on the edge of a single circle. It is also impossible to calculate if the included angle between the known points is too small. It is difficult to imagine that the longer the distance between the instrument occupied and known points, the narrower the included angle between the known points.

It is sometimes impossible to perform a correct calculation such as shown below.

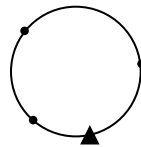

When they are on the edge of a single circle, take one of the following methods:

(1) Move the instrument station as close as possible to the center of the triangle.

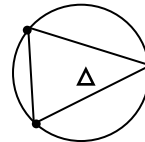

(2) Measure one more known point which is not on the circle.

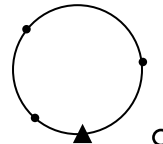

(3) Perform a distance measurement on at least one of the three points.

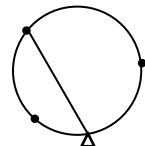

8.8. Point projection

Point projection is used for projecting a point to an established baseline. The point to project can be either measured or input. Displays the distances from the first point and point to project to the position at which a line extending from point to project intersects the baseline at right angles.

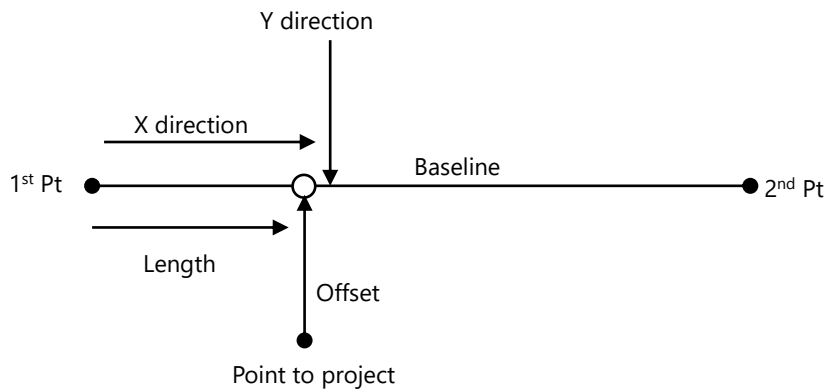

Length: Distance along the baseline from 1st point to 2nd point (X direction).

Offset: Distance from point to project to the position at which a line extending from point of project intersects the baseline at right angles (Y direction).

8.8.1. Define baseline

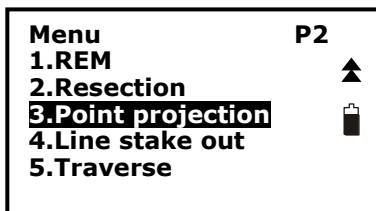

Press [MENU] softkey in the basic measurement mode.
Turn to P2, select "3. Point projection".

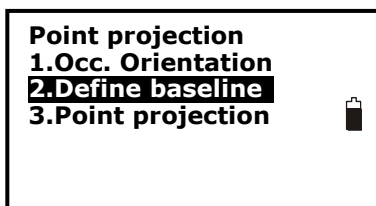

After having set the station (refer to 7.2. Set the station), select "2. Define baseline".

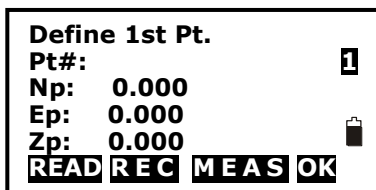

Input the first point data or press F1[READ] to use existed coordinates data. Press F3[MEAS] to measure the point and F2[REC] to memorize it.
Press F4[OK] to input the second point data.

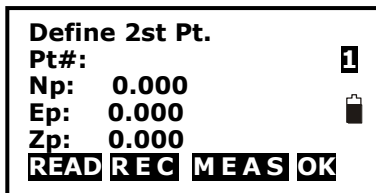

In the same way, define the second point and press F4[OK] to finish defining baseline. The grade of the baseline will display.

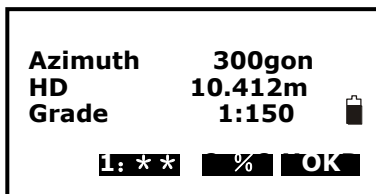

Press F2[1:**] or F3[%] to change the grade display mode.

8.8.2. Point projection

The baseline must be defined before performing point projection.

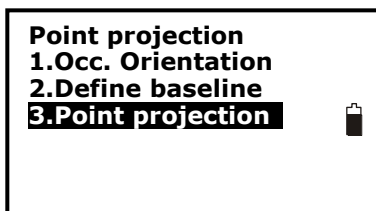

Select "3. Point projection" after finishing defining baseline.



Input the point coordinate or press F1[READ] to use existed coordinates data.

Press F2[MEAS] to measure the point to project.

When recording the data as a known point, press {Func} key, and press F2[REC] on P2. Press F4[OK] to calculate.

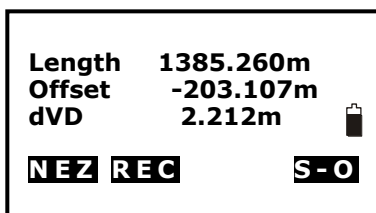

Length, Offset and dVD will display.

Length: Distance along the baseline from 1st point to 2nd point (X direction).

Offset: Distance from point to project to the position at which a line extending from point of project intersects the baseline at right angles (Y direction)

dVD: Elevation between the baseline and the projected point

Press F1[NEZ] to display switching between coordinate and distance data.

Press F2[REC] to record the coordinate as a known data.

Press F4[S-O] to switch to stake out measurement of the projected point.

See 8.2. Stake out measurement.

Press {ESC} key to continue point projection of a new point.

8.9. Stake out line

Stake out line is used for staking out a required point at a designed distance from the base line and for finding the distance from the baseline to a measured point.

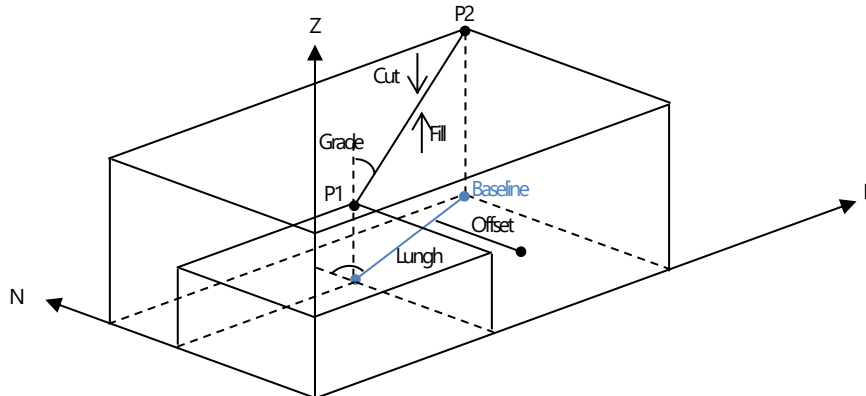

8.9.1. Define baseline

To perform stake out line, please define a baseline first. The baseline can be defined by inputting coordinates of the two points.

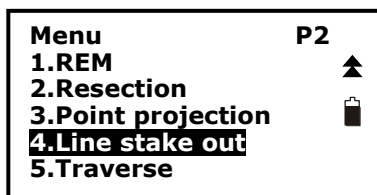

Press [MENU] softkey in the basic measurement mode.

Turn to P2 through the {Func} key and select "4. Stake out line".

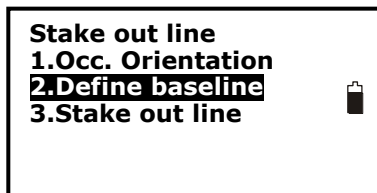

Input the instrument occupied data, see 7.2. Set the station, then select "2. Define baseline".

8.9.2. Stake out line-point

This measurement can be used to find the required point coordinates by inputting the length and offset based on baseline.

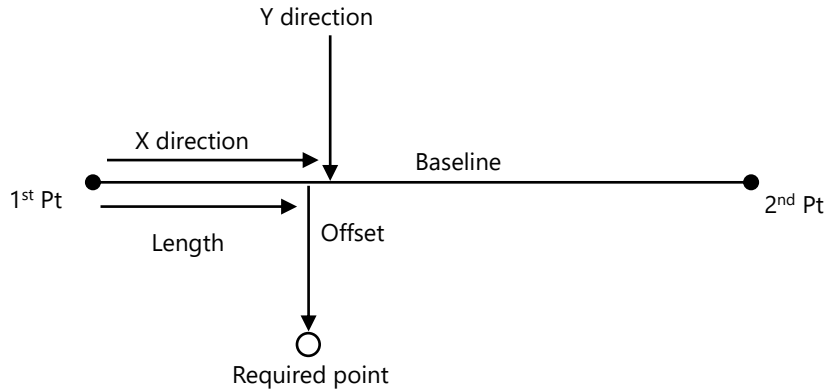

Length: Distance along the baseline from 1st point to the position at which a line extending from the required point intersects the baseline at right angles (X direction)

Offset: Distance from the required point to the position at which a line extending from the required point intersects the baseline at right angles (Y direction).

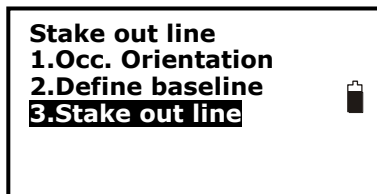

Select "3. Stake out line" after defining a baseline.

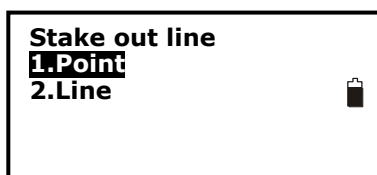

Select "1. Point"

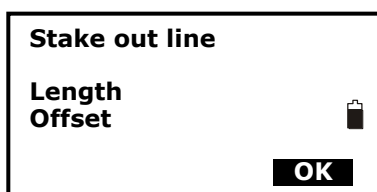

Input values of length and offset, then press F4[OK], the coordinate of the required point is calculated and displayed.

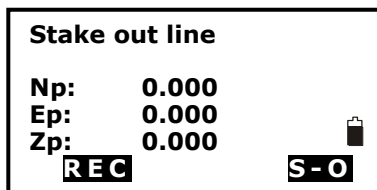

Press F2[REC] to record the value as a known point.

Press F4[S-O] to stake out the required point, see 8.2. Stake out measurement.

Press {ESC} key to continue.

8.9.3. Stake out line-line

Stake out line-line tells how far horizontally the measured point is from the baseline and how far vertically the measured point is from the connected line. Make sure to define a baseline before this operation.

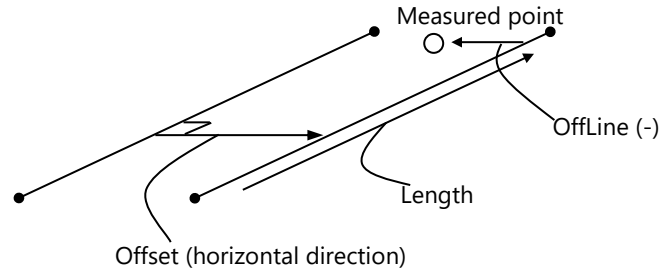

Profile view:

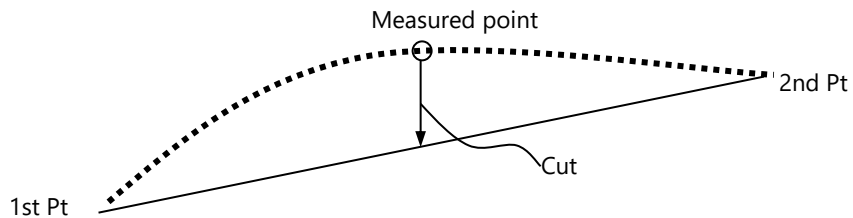

Offline: A positive value indicates the point is on the right of the baseline and a negative value indicates it is on the left.

Cut: indicates that the point is below the baseline.

Fill: indicates that the point is above the baseline.

Length: distance along the baseline from 1st point to the measured point.

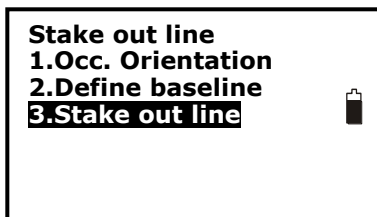

Select "3. Stake out line" after defining a baseline.

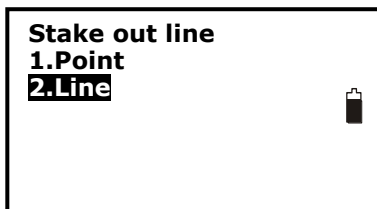

Select "2.Line".

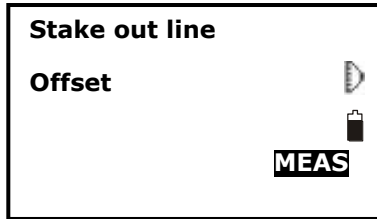

Input offset value: the horizontal move distance of baseline, right side indicates positive value and left side indicates negative value.

Aim at the target and press F4[MEAS] to measure. The measured results are displayed.

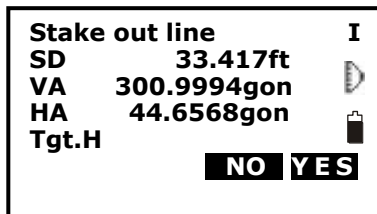

Press F3[NO] to re-measure the target.

Press F4[YES] to use the measured values. The difference between the measured data and the baseline displays:

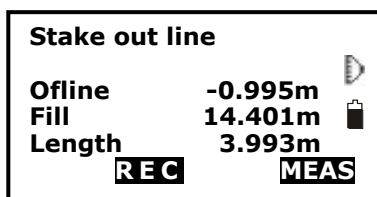

Offline: A positive value indicates the point is on the right of the baseline and a negative value indicates it is on the left.

Cut: indicates that the point is below the baseline.

Fill: indicates that the point is above the baseline.

Length: Distance along the baseline from the first point to the measured point.

Aim at the next target and press F4[MEAS] to continue the measurement.

8.10. Traverse surveying

Measure the coordinate of foresight point and save it in the list, this point would be taken as the occupied point after transferring to point 2, and the previous occupied point will be taken as the backsight point, the azimuth angle will be calculated and set.

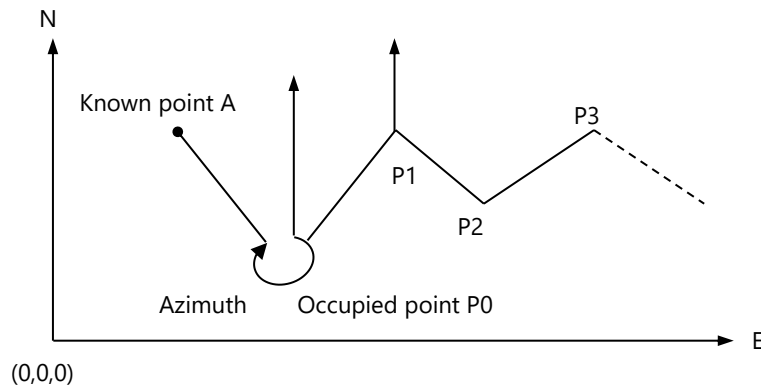

8.10.1. Save coordinate

Here is the operation of how to measure the foresight point and save it in the list.



Press [MENU] softkey in the basic measurement mode.
Turn to P2, select "5.Traverse".

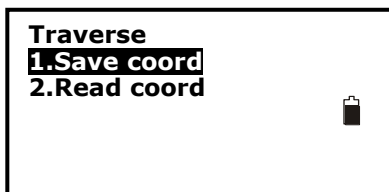

Press "1.Save coord".

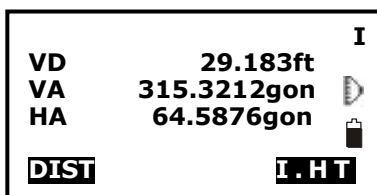

Aim at the target point and then press F1[DIST]. You can press F4[I.H.T] to re-input instrument height or target height here.

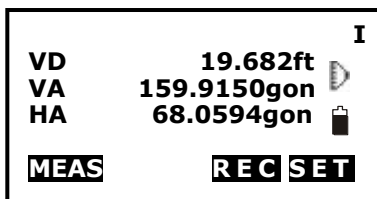

Press F4[SET] to set the data or press F3[REC] to record it in the list.

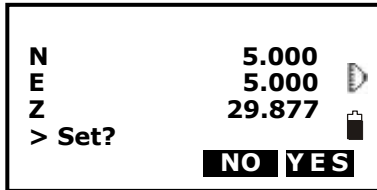

Press F3[NO] back to the previous mode and press F4[YES] to set the data.

8.10.2 Read coordinate

Set the measured foresight point in the saved coordinates list as the occupied point, and the previous occupied point becomes the back point.

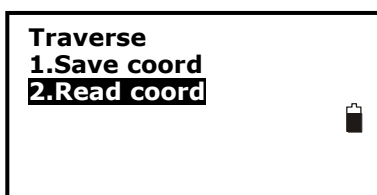

Move the instrument to the measured foresight point.
Select "2. Read coord".

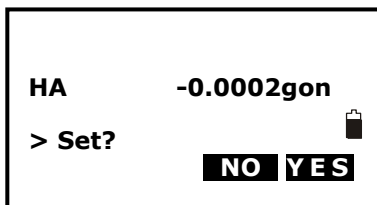

First aim the previous occupied point, then press F4[YES] to set the previous foresight point coordinate as the occupied point coordinate or press F3[NO] to give up.

8.11. Inverse

The distance and azimuth from a start point to an end point could be calculated according to input their coordinates.

Input:

Coordinate of start point: N0, E0, Z0

Coordinate of end point: N1, E1, Z1

Output:

Distance: D

Azimuth: Az

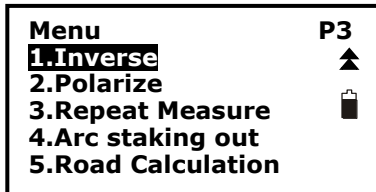

Press [MENU] softkey in the basic measurement mode.

Turn to P3, select "1. Inverse".

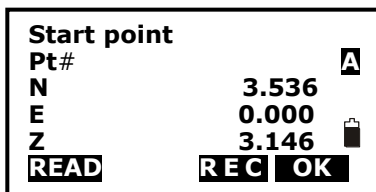

Input coordinates of the start point and press F3[REC] to record the data in the list. You could press F1[READ] to read the existed data. Press F4[OK] to set.

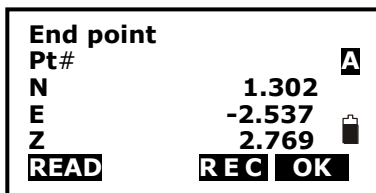

Input coordinates of the end point. See the previous step.

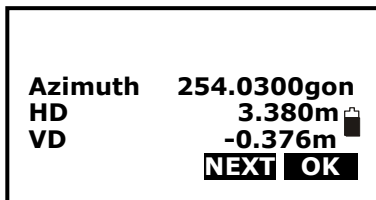

The inversed value will display. Press F3[NEXT] to continue, press F4[OK] back to menu mode.

8.12. Polar coordinates calculation

The coordinates of the end point could be calculated according to input azimuth, distance and the NEZ coordinates of start point.

Input:

Coordinate of start point: N_0, E_0, Z_0

Azimuth: Az

Distance: D

Output:

Coordinate of end point: N_1, E_1, Z_1

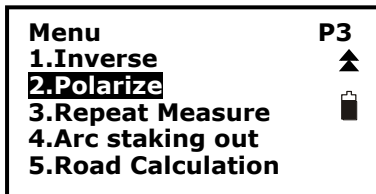
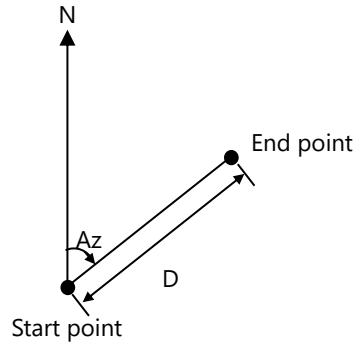

Press [MENU] softkey in the basic measurement mode.

Turn to P3, select "2. Polarize".

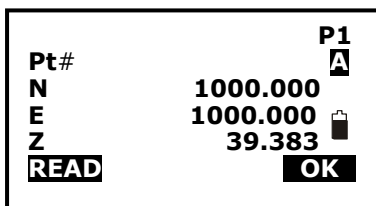

Input the data in corresponding items. You could press F1[READ] to read the existed coordinate data for start point. Press F4[OK] to enter.

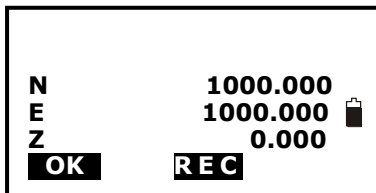

The calculated data displays. Press F3[REC] to record it in the list and press F1[OK] back to menu mode.

8.13. Repetition angle measurement

Repetition angle measurement can be done by horizontal angle right measurement mode.

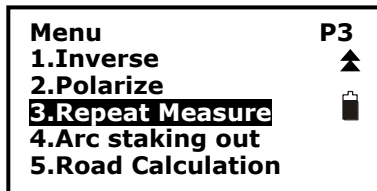
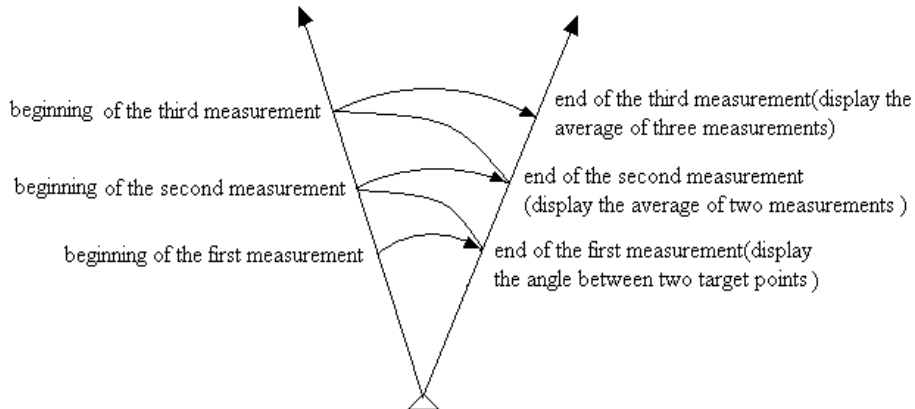

Press [MENU] softkey in the basic measurement mode.
Turn to P3, select "3. Repeat Measure".

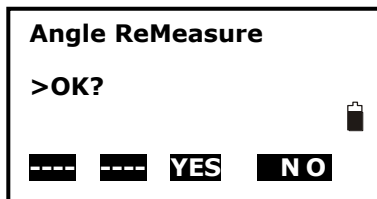

Press the F3[YES] key.

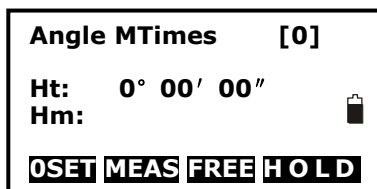

Collimate the target A and press the F1[OSET] key.
Press the F3[Yes] key.

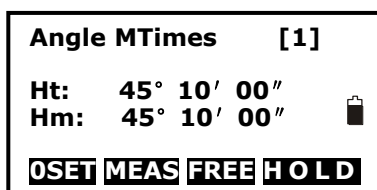

Collimate the target B using the horizontal clamp and tangent screw.
Press the F4[HOLD] key.

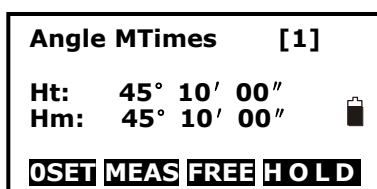

Re-collimate the target A using the horizontal clamp and tangent screw
and press the F3[FREE] key.

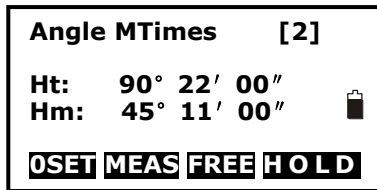

Re-collimate the target B using the horizontal clamp and tangent screw, press the F4[HOLD] key. On the display:

Ht: is the accumulated angle measurement

Hm: is the averaged angle measurement

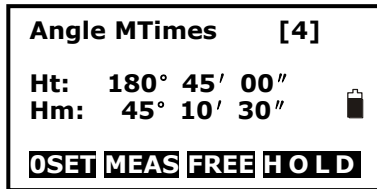

Repeat to measure the desired number of repetition.

Press F2[MEAS] or {ESC} keys to leave the program.

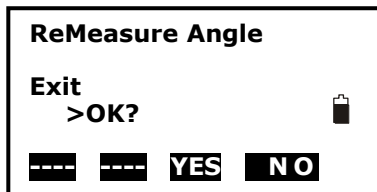

Press the F3[YES] key.

NOTE:

- Horizontal angle can be accumulated up to 3600°00'00" – minimum reading. In case of 5 second reading, horizontal angle can be accumulated up to +3599°59'55".
- Error will be displayed when the results differ from first measurement by more than ±30".

8.14. Arc staking out measurement

This application permits the user to define a reference arc by 2 points and a radius or by 3 points and, then, to stake out in relation to the arc.

Menu	P3
1.Inverse	▲
2.Polarize	
3.Repeat Measure	🔋
4.Arc staking out	
5.Road Calculation	

Press [MENU] softkey in the basic measurement mode.

Turn to P3 through the {Func} key and select "4. Arc staking out".

Arc Stakeout	
1.Occ.Orientation	
2.2pt+radius arc	🔋
3.Three point arc	

Input the instrument occupied data, refer to 7.2. Set the station.

It will automatically turn to the arc stakeout menu. Here, select how to define the arc.

8.14.1. 2pt+radius arc staking out

Arc Stakeout	
1.Occ.Orientation	
2.2pt+radius arc	🔋
3.Three point arc	

On arc staking out menu select "2. 2pt+radius arc" to start 2-point arc staking out measurement.

Define/Start PT	
Pt#	
Np :	4.000
Ep :	7.000 🔋
Zp :	2
READ	REC MEAS OK

Input the coordinate of arc start point or select them from memory using F1[READ] key. Press F3[MEAS] to determine start point by measuring.

Press [OK] to set data and continue.

Define/End PT	
Pt#	
Np :	7.000
Ep :	5.000 🔋
Zp :	9
READ	REC MEAS OK

In the same way, input the coordinate of arc end point.

Arc define/Rad Input	
Rad	4.000m 🔋
	S.O. MEAS

Input the radius of arc and decide to Measure or Stake Out:

F4[MEAS]: Activates Line & Offset measuring.

F3[S.O.]: Starts the program to stake out.

NOTE : When the arc radius is positive, if the MP has deviation (OfLine), then it must be outside the arc. When the arc radius is negative, if the MP has deviation, then it must be inside the arc.

Measure

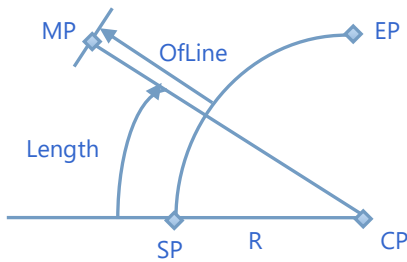

SP: Start point of arc
 EP: End point of arc
 CP: Centre point of circle
 MP: Measured point
 R: Radius of circle
 Length: Distance from start of arc along with the curve
 OfLine: Vertical distance from arc

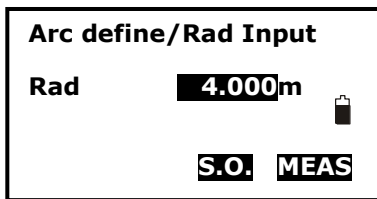

Press F4[MEAS] to enter the measure mode.

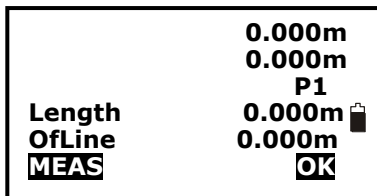

Then press F1[MEAS] to measure current rod (MP).

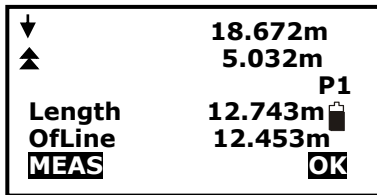

As figure shows:

Length: distance from start point of arc along with the curve.
 OfLine: vertical distance from arc.

Stake out function

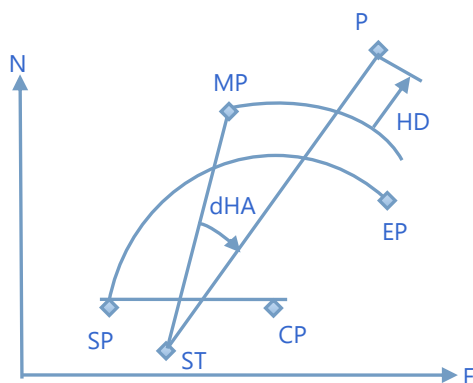

ST: Station
 SP: Start point of arc
 EP: End point of arc
 CP: Centre point of circle
 P: Point to stake out
 MP: Measured point
 dHA: Difference in horizontal angle
 HD: Difference in distance measurement

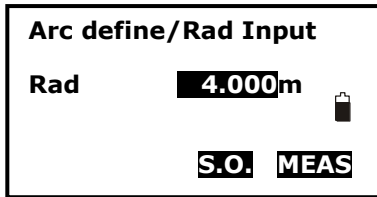

Press F3[S.O.] to enter the stake out mode.

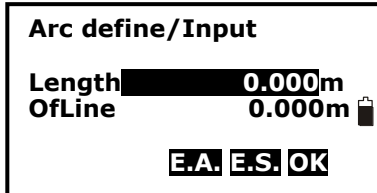

As figure shows, three types of stake out measures are possible:

- Equal arc stake out: Press F2[E.A.]
- Equal string stake out: Press F3[E.S.]
- Normal arc stake out: Press F4[OK]

NOTE: Before starting staking out, it is useful to change the EDM setting, applying "Tracking" as mode, in order to have a higher number of measurements. For more details about the EDM, refer to 5.2. EDM settings.

1. Normal arc stake out

This allows to stake out a point by entering a length and an OfLine.

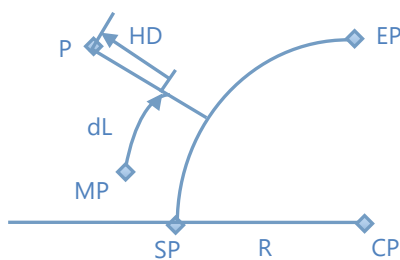

- SP: Start point of arc
- EP: End point of arc
- CP: Centre point of circle
- P: Point to stake out
- MP: Measured point
- dL: Distance from MP along with the curve
- HD: Difference in distance measurement between MP and P

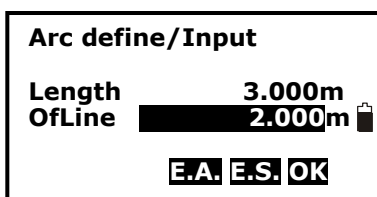

In "Arc define/ Input" dialog enter "Length" and "OfLine" values and press F4[OK].

The stake out result will display as shown in below figure.

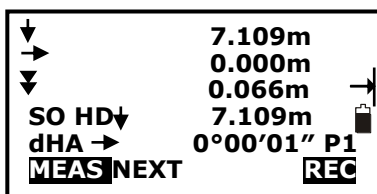

↓ : Represents HD and indicates moving the rod (prism) in station direction.

→ : Represents dL and indicates moving the rod (prism) in right direction. When this value goes to "0", the direction instrument faces is just the direction to stake out.

▼ : This value indicates that the rod is higher than the arc. Indicates moving the prism downwards.

SO HD: Difference in distance measurement between measured and stake out points.

dHA: Difference in horizontal angle. When this value goes to "0", the

direction instrument faces is just the direction to stake out.

Use F1[MEAS] to start measuring: rotate the instrument and move the prism. When the values on the display are "0", the stake out point is found.

2. Equal arc stake out

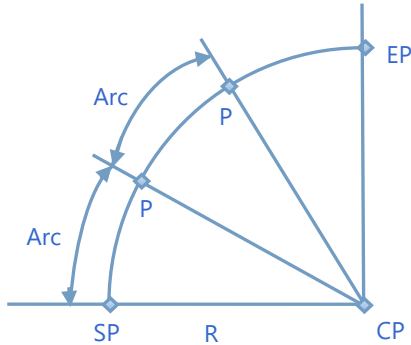

This program completes the staking out progress by dividing the arc between start point and end point into several parts.



- SP: Start point of arc
- EP: End point of arc
- CP: Centre point of circle
- R: Radius of circle
- P: Point(s) to stake out
- Arc: Arc length

Arc define/Input	
Length	0.000m
OfLine	0.000m 
E.A. E.S. OK	

In "Arc define/ Input" dialog press F2[E.A.].

Arc define/Input	
Arc	4.000m 
OfLine	0.000m 
S.O. E.S. OK	

Input arc length and offset distance.

After pressing F4[OK], the stake out result will display.

↓	28.227m	1
←	6.926m	
↓	0.968m	→
SO HD ↓	10.780m	
dHA ←	136°41'47"	P1
MEAS PT+ PT- REC		

Press F2[PT +] or F3[PT -] keys to toggles through the calculated stake out points. When up-right number is "0", it means start point, when up-right number is "1", it means the first equal arc point and so on.

Press F1[MEAS] to start measuring: rotate the instrument and move the prism. When the values on the display are "0", the stake out point is found.

The contents of stake out result can refer to normal arc stake out.

3. Equal string stake out

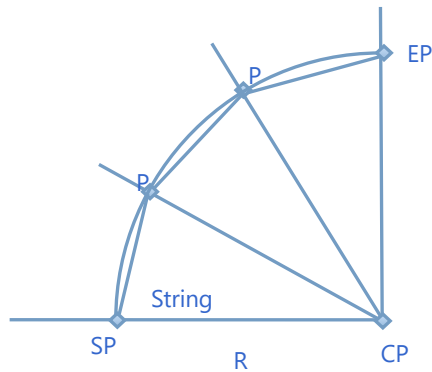

SP: Start point of arc
 EP: End point of arc
 CP: Centre point of circle
 P: Point to stake out
 String: Chord length

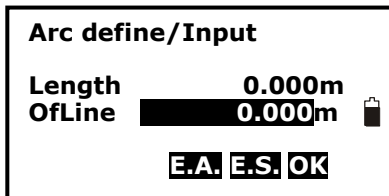

In "Arc define/ Input" dialog press F2[E.S.].

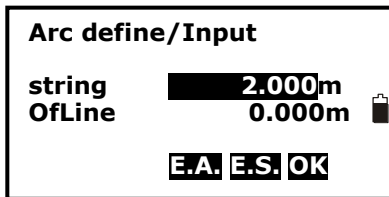

Then input string length and offset distance.
 After pressing F4[OK], the stake out result will display.

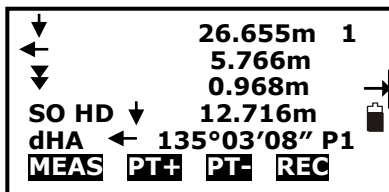

Press F2[PT +] or F3[PT -] keys to toggles through the calculated stake out points. When up-right number is "0", it means start point, when up-right number is "1", it means the first equal arc point and so on.

Press F1[MEAS] to start measuring: rotate the instrument and move the prism. When the values on the display are "0", the stake out point is found. The contents of stake out result can refer to normal arc stake out.

8.14.2. Three point arc staking out

```

Arc Stakeout
1.Occ.Orientation
2.2pt+radius arc
3.Three point arc
  
```

On arc staking out menu select "3. Three Point Arc" to start 3-point arc staking out measurement.

```

Define/Start PT
Pt#
Np :      102.000
Ep :      100.000
Zp :      100
READ REC MEAS OK
  
```

Input the coordinate of arc start point or select them from memory using F1[READ] key. Press F3[MEAS] to determine start point by measuring.

Press [OK] to set data and continue.

```

Define/End PT
Pt#
Np :      98.000
Ep :      100.000
Zp :      100
READ REC MEAS OK
  
```

In the same way, input the coordinate of arc end point.

```

Arc define/Mid PT
Pt#
Np :      100.000
Ep :      102.000
Zp :      100.000
READ REC MEAS OK
  
```

and of arc Mid point, which is a random point on arc except start point and end point.

```

Arc define/Input
Length      0.000m
OfLine     0.000m
E.A. E.S. OK
  
```

After, it will enter "Arc define/Input" display. Specific operations are the same as described in 8.14.1. 2pt+radius arc staking out

8.15. Road staking out measurement

This program is especially designed for Road Layout measurement. It can be used for horizontal curve layout. Normally one road is constituted by several elements, such as line, circle curve or Spline.

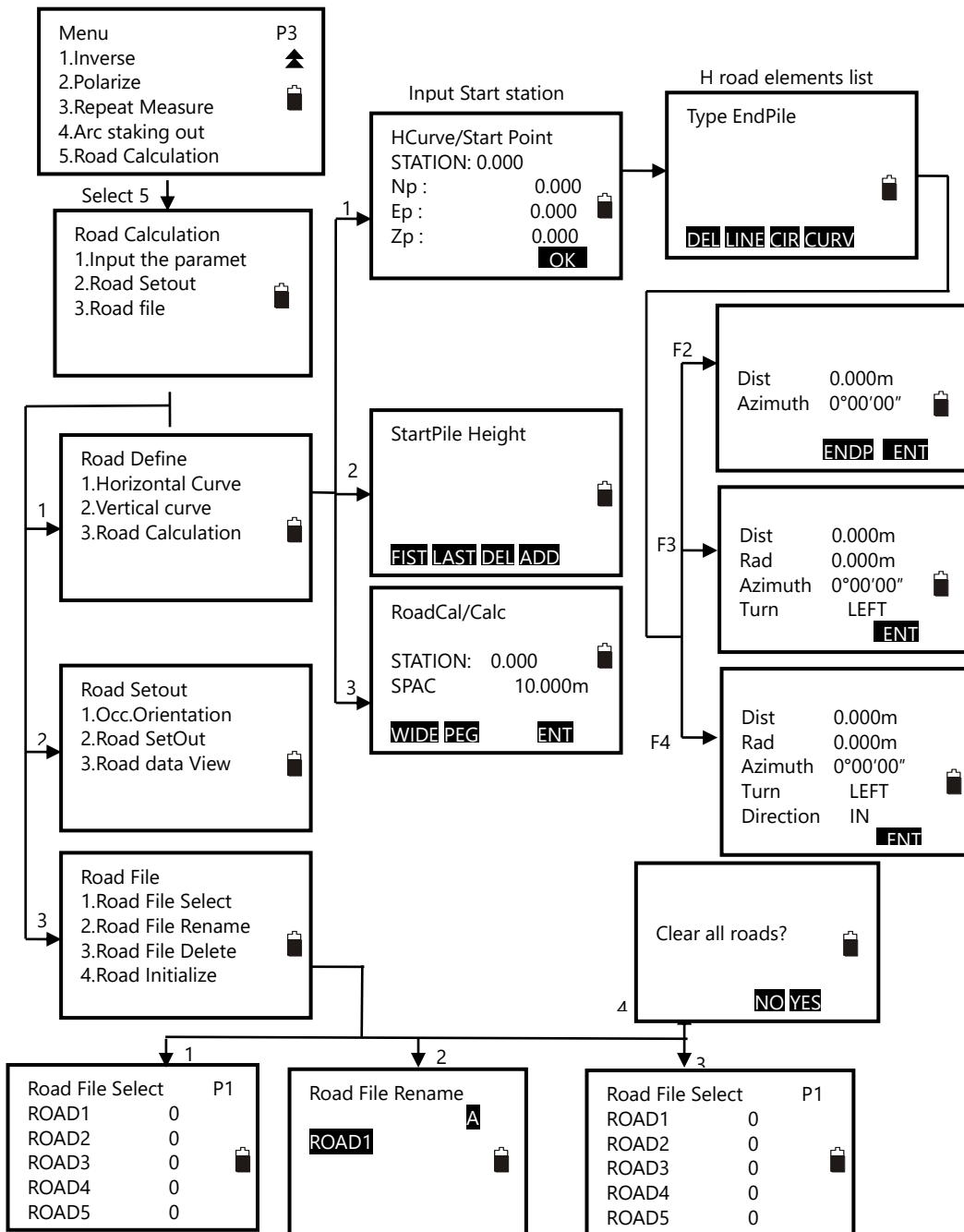

8.15.1. Input the start station

Menu	P3
1.Inverse	▲
2.Polarize	☰
3.Repeat Measure	☰
4.Arc staking out	☰
5.Road Calculation	

Press [MENU] softkey in the basic measurement mode.
Turn to P3 through the {Func} key and select "5. Road Calculation".

Road Calculation
1.Input the parameter
2.Road Setout
3.Road file

Select "1. Input the parameter" to enter road define menu.

Road Define
1.Horizontal Curve
2.Vertical curve
3.Road Calculation

Select "1. Horizontal Curve", start point entering menu will display.

HCurve/Start Point
STATION: 0.000
Np : 0.000
Ep : 0.000
Zp : 0.000
OK

Enter the start point station and coordinate, press F4[OK] key.

Type EndPile
DEL LINE CIR CURV

Road horizontal elements editing menu will display.

8.15.2. Input road horizontal elements

Type EndPile
DEL LINE CIR CURV

Three types elements can be input:

- Lines: press F2[LINE];
- Curves: press F3[CIR];
- Spline: press F4[CURV].

Input line element

Dist	100m
Azimuth	0°00'00"
ENDP	ENT

Input the line length and azimuth in the Dist and Azimuth filed. Press F4[ENT] key to confirm.

You can press F3[ENDP] to enter the end point inputting menu.

Type EndPile	
Line	100.000
	
DEL	LINE
CIR	CURV

Automatically, it turns to page where all the horizontal road elements are listed.

Here "EndPile" means the end station of this element.

Dist	100m
Azimuth	0°00'00"
	
ENDP	ENT

To input the end point, press F3[ENDP].

NOTE: the end point can be inserted only as line element.

Line Input/END POINT	
Pt#	A
N	100m
E	0.000m
Z	0.000m
	
READ	LEN
	ENT

Input the end point coordinate directly or press F1[READ] to recall from memory.

Press F4[ENT] to confirm, you will see the line element in the list menu.

Press F3[LINE] to back to the LENGTH menu

Input circle element

Dist	100.000m
Rad	100.000m
Azimuth	0°00'00"
Turn:	RIGHT
	
	ENT

Input the curve parameters, including length (Dist), radius (Rad), azimuth and turn. Press F4[ENT] key to confirm.

Type EndPile	
Line	100.000
Circle	200.000
	
DEL	LINE
CIR	CURV

NOTE:

- Normally the azimuth will calculate and display following previous element.
- When you set the turn, move the cursor to [Turn] item, press ◀/▶ keys to shift between Left and Right.

Input spiral element

Dist	100.000m
Rad	100.000m
Azimuth	57°17'44"
Turn	RIGHT
Direction	IN
	
	ENT

Input the curve parameters, including length (Dist), radius (Rad), azimuth, turn and direction.

Press F4[ENT] key to confirm, back to the horizontal elements menu.

Type	EndPile
Line	100.000
Circle	200.000
Spiral	300.000

DEL **LINE** **CIR** **CURV**

Once defined all the horizontal elements, press {ESC} key.

NOTE:

- Normally the azimuth will calculate and display following previous element.
- When you set the turn or direction, move the cursor to [Turn] or [Direction] item, press ◀/▶ keys to shift the options.
- If you set the Direction is IN, here the inputted Rad is End radius of spiral, its start radius is default as ∞; if you set the direction is OUT, here the inputted is start radius of spiral, its end radius is default as ∞.

Road horizontal element editing

In the horizontal element editing menu, the inputted element can be edited.

- Delete horizontal element

Type	EndPile
Line	100.000
Circle	200.000
Spiral	300.000
Circle	400.000

DEL **LINE** **CIR** **CURV**

Move ▲/▼ keys, the cursor will move to different element.

Press F1[DEL] to delete the selected element, the two elements adjacent with deleted one will connect automatically.

- Edit horizontal element

Type	EndPile
Line	100.000
Spiral	200.000
Circle	300.000
Spiral	400.000

DEL **LINE** **CIR** **CURV**

Move ▲/▼ keys, the cursor will move to different element.

Press {ENT} key to edit the selected element.

Dist	200.000m
Rad	100.000m
Azimuth	0°00'00"
Turn	RIGHT
Direction	IN

ENT

Press F4[ENT] key to confirm, other elements following the edited one will upgrade automatically.

Type	EndPile
Line	100.000
Spiral	300.000
Circle	400.000
Spiral	500.000

DEL **LINE** **CIR** **CURV**

After all the horizontal elements are confirmed, press [ESC] key to go back to previous menu.

8.15.3. Input road vertical elements

Road vertical elements is confirmed by some intersection points, you should input same parameters for the intersection points, including station, height, and length from this intersection point to next intersection point.

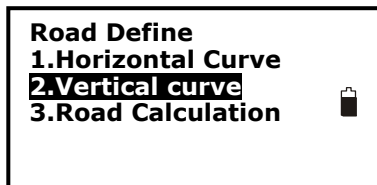
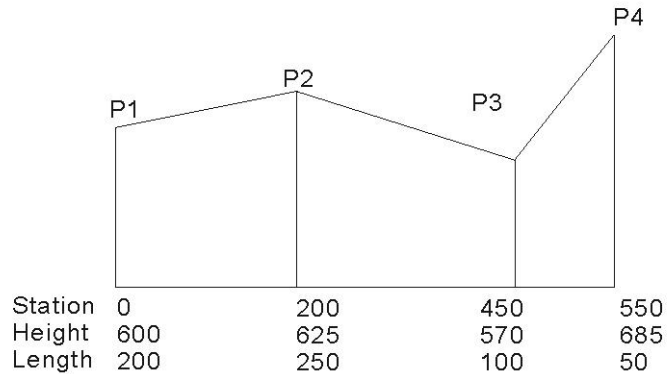

Select "2.Vertical Curve".

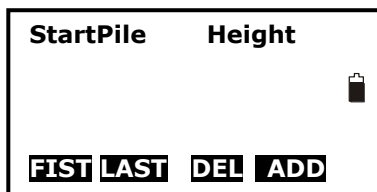

Here:

Press F1[F1ST] key, the cursor will move to the first element.

Press F2[LAST] key, the cursor will move to the last element.

Press F3[DEL] key to delete the selected element.

Press F4[ADD] key to add a new vertical element.

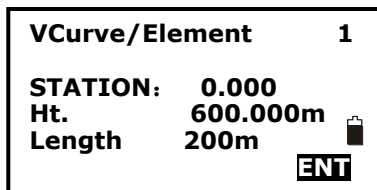

For a new vertical element, define height (Ht.), distance (Length). Station is automatically evaluated basing on previous elements length.

Press F4[ENT] key to confirm.

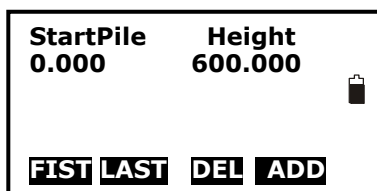

The new element is in the vertical elements menu.

Repeat the previous step to input all the vertical elements for the road.

Edit vertical road element

In the horizontal element editing menu, the inputted element can be edited.

- Delete vertical element

StartPile	Height
0.000	600.000
200.000	625.000
400.000	570.000
500.000	685.000
F1ST	LAST
DEL	ADD

Move F1[F1ST], F2[LAST], ▲/▼ keys, the cursor will move to different element.

Press F3[DEL] to delete the selected element, the two elements adjacent with deleted one will connect automatically.

StartPile	Height
0.000	600.000
200.000	570.000
300.000	685.000
F1ST	LAST
DEL	ADD

For example, after deleting the second element, the vertical road curve figure is shown below:

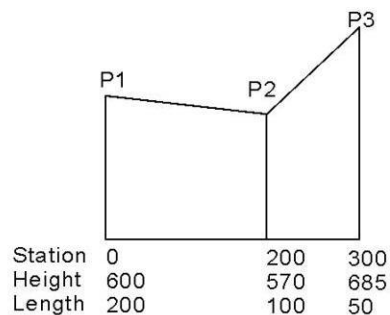

- Edit horizontal element

StartPile	Height
0.000	600.000
200.000	625.000
400.000	570.000
500.000	685.000
F1ST	LAST
DEL	ADD

Move ▲/▼ keys, the cursor will move to different element.

VCurve/Element	
STATION:	200.000
Ht.	625.000
Length	180 m
ENT	

Press {ENT} key to edit the selected element.

StartPile	Height
0.000	600.000
200.000	625.000
380.000	570.000
480.000	685.000
F1ST	LAST
DEL	ADD

Press F4[ENT] key to confirm, other elements following the edited one will upgrade automatically.

After all the horizontal elements are confirmed, press [ESC] key back to previous menu.

For example, after edit the second element, the vertical road curve figure is shown below:

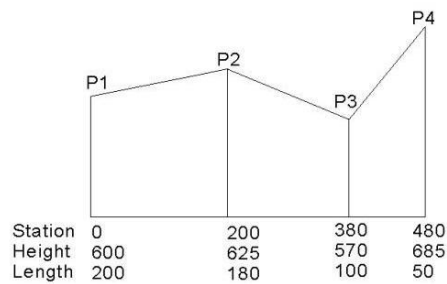

8.15.4. Road calculation

Input the road width element

```

Road Define
1.Horizontal Curve
2.Vertical curve
3.Road Calculation
    
```

Select "3. Road Calculation".

```

RoadCal/Calc
STATION:0.000
SPAC 0.000 m
WIDE PEG ENT
    
```

Press F1[WIDE] to road width setting menu.

```

SPile LW
FIST LAST DEL ADD
    
```

Press F1[FIST] key, the cursor will move to the first element.
 Press F2[LAST] key, the cursor will move to the last element.
 Press F3[DEL] key to delete the selected element.
 Press F4[ADD] key to add a new vertical element.

```

Wide Input 1
STATION: 0.000m
Lwide 3.000m
Rwide 4.000m
ENT
    
```

Press F4[ADD] to enter road wide inputting menu. Input the parameters of road width:

STATION: the road will take this width begin from this point to next road width element

Lwide: left width

Rwide: right width

Press F4[ENT] key to confirm.

Repeat the previous step to input another road width.

```

SPile LW
0.000 3.000
100.000 5.000
300.000 6.000
FIST LAST DEL ADD
    
```

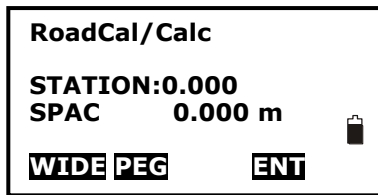

Press [ESC] back to road calculation menu.

Additional station setting

Some special stations can be calculated and stake out, the setting procedures are same with road width element inputting, but their result are different; for road width element, the inputted parameters are available from setting station to next element, but for additional station setting, the inputted parameters are available only for setting station.

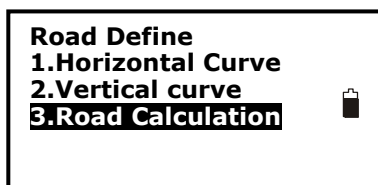

Select "3.Road Calculation".

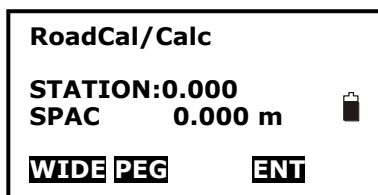

Press F2[PEG] to enter additional station setting menu.

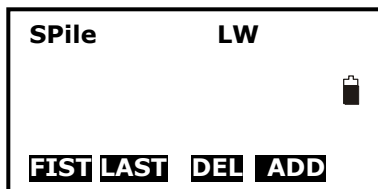

Press F1[FIST] key, the cursor will move to the first element.
 Press F2[LAST] key, the cursor will move to the last element.
 Press F3[Del] key to delete the selected element.
 Press F4[ADD] key to add a new vertical element.

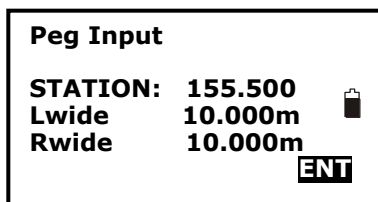

Press F4[ADD] to enter road wide inputting menu and input the parameters of road width:

STATION: the road will take this width begin from this point to next road width element

Lwide: left width

Rwide: right width

Press F4[ENT] key to confirm.

Repeat the previous step to input another road width.

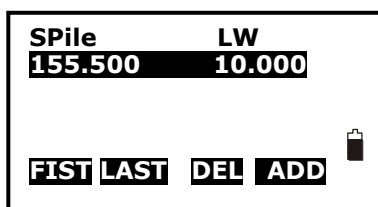

Press [ESC] back to road calculation menu.

Road calculation

After design the road, input the interval to calculate the staking points.

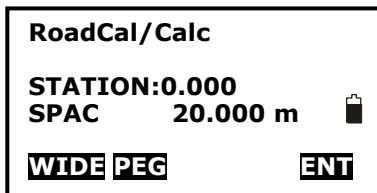

Input the interval of staking points on the road in the "SPAC" field.

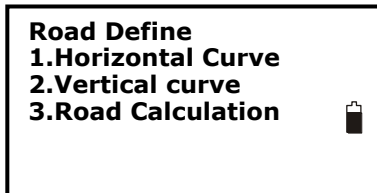

Press F4[ENT] to calculate, "calculating" will display until "Cal complete" appear, the program goes back to previous menu automatically.

NOTE: If the following display is shown, it means that some staked points exist in this file already. Press F3[YES] key to cover these points or press F4[NO] back to previous screen.



8.15.5. Road stake out

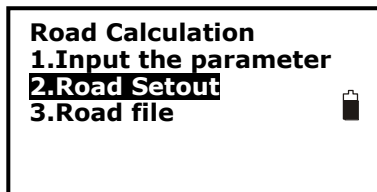

Select "2.Road SetOut" in the road calculation menu.

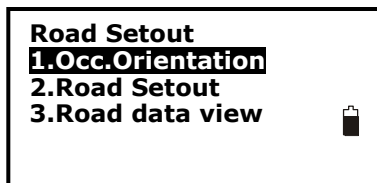

After having set the station (refer to 7.2. Set the station), select "2. Road Setout" to stake out road, the first center station of road will display.

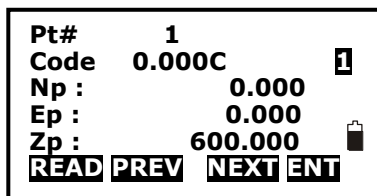

Press F1[READ] key to open the station list: select the point and press {ENT}.

Here:

Pt#: Station serial number

Code: Station mileage, "C" means center station, "R" means right station, "L" means left station.

Press F2[PREV] or F3[NEXT] keys to display previous or next station.

Press F4[ENT] to enter coordinate staking out screen.

For the procedure, refer to 8.2.2. Coordinates stake out measurements.

8.15.6. Road staking out data view

After design and calculate the road, all the staking points can be view.

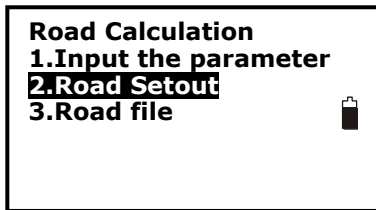

In the Road calculation menu, select "2.Road Setout".

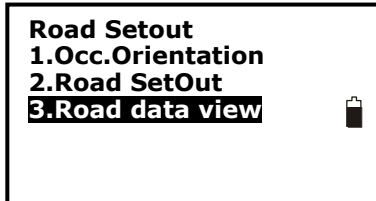

Select "3.Road data view" to view the staking station data:



The station list will display.

Here:

STAKE: Center station serial number

RSTAKE: Right station serial number

LSTAKE: Left station serial number

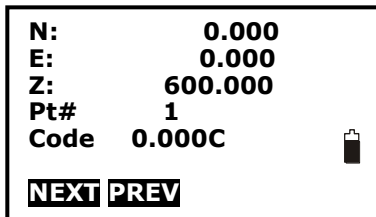

Press the {ENT} key to display the coordinate of selected station. Here:

Pt#: Station serial number

Code: Station mileage, "C" means center station, "R" means right station, "L" means left station.

Press F1[NEXT] key to display next station, F2[PREV] key to display previous station.

8.15.7. Road file management

All the elements you inputted and the staking data you calculated are recorded in the current road file. You can select another file to define other road, normally one file includes one road.

NOTE:

- There are 10 road files in total, the factory default setting is "ROAD1".
- The default names are "ROAD1", "ROAD2" ... "ROAD10", you can rename them if necessary.

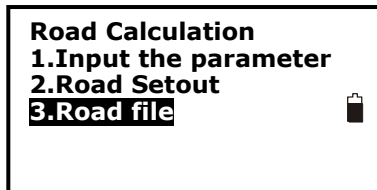

Select "3.Road file" in road calculation menu.

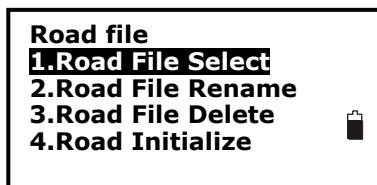

Select a road file

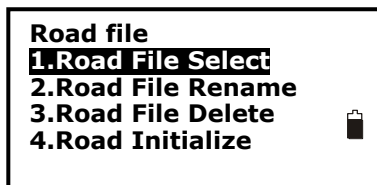

Select "1.Road File Select" to display road file list, the cursor will stay on current Job file.

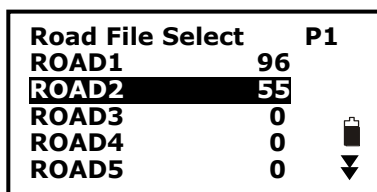

Press ▼/▲ keys to move cursor, after reach to the job you want to select, press [ENT] key to confirm. The program will back to road file management menu automatically.

Rename a road file

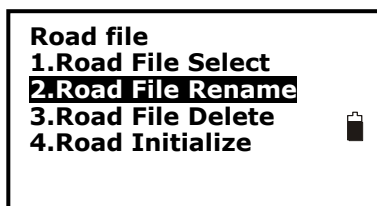

Select 2.Road File Rename, current road file will display.

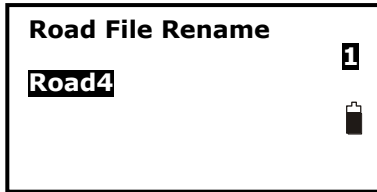

Input new name, press [ENT] key to confirm. The program will back to road file management menu automatically.

NOTE: The max length of road file name is 8 characters, special symbols cannot be accepted, such as "#, ? /....."

Delete a road file

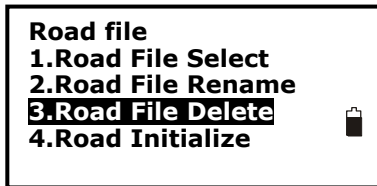

Select "3.Road File Delete", road file list will display.

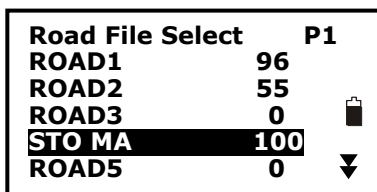

Press ▼/▲ keys to move cursor, after reach to the job you want to delete, press {ENT} key.

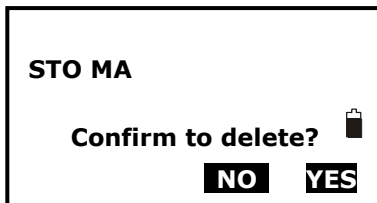

It will be asked you to confirm to delete, press F3[NO] back to file list, the file will not be deleted.

Press F4[YES] to delete this file, all the inputted and calculated data in this file will be cleared, and the file name change to initial status.

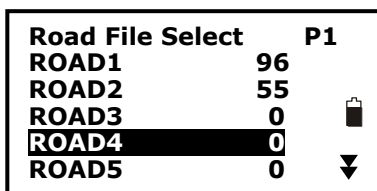

Delete all road files

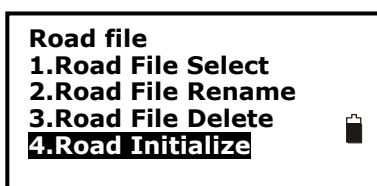

Select "4.Road Initialize". it will ask you to confirm to clear all roads, press F3[NO] back to road file management menu, no file is deleted.



Press F4[YES] to delete all road files.

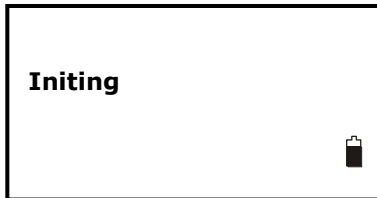



"Initing" will display, at last it will back to road file management menu automatically.

NOTE:

Pay more attention to this operation, after initialization, all the files back to initial status, the deleted elements and data can not be resumed.

9. Record

You can record measured data, occupied data and notes into the active JOB. The memory is 60000 points in total.

Meas	ppm 0	
SD	3.642m	
VA	302.5432gon	
HA	0.0000gon	P3
EDM	OCC	OFST REC

In basic measurement mode, press the {Shift} key to scroll the softkeys in the bottom of the display, until [REC] is shown. Select it to enter record mode. The active JOB will display.

REC	JOB1	P1
1.Occ. data		
2.Angle data		
3.Collect Points		
4.Note		
5.View		



REC	JOB1	P2
1.JOB select		
		

9.1. Record occupied data

You can input occupied data into the active JOB. The record items include: occupied coordinates, point number, instrument height, code, user, date, time, weather, wind, temperature, air pressure and ppm. If the current occupied data have not been recorded in the active JOB, the previous occupied data will be used as the active one.

REC	JOB1	P1
1.Occ. data		
2.Angle data		
3.Collect Points		
4.Note		
5.View		

Select "1. Occ. data" to set occupied station.

Pt#	J2	
Inst.H	0.000m	
N0:	0.000	
E0:	0.000	
Z0:	0.000	
READ	RES	REC OK

Refer to 7.2. Set the station for the procedure

9.2. Collect angle data

```

REC  JOB1      P1
1.Occ. data
2.Angle data
3.Collect Points
4.Note
5.View
  
```

Select "2. Angle data".

```

REC  Free 44000  II
VA   148.7080gon
HA   352.4228gon
Pt#  P1
AUTO OSET      REC
  
```

Aim at the target: the angle will display in real time.

Press F2[OSET] to set horizontal angle as 0.

```

REC  Free 44000  II
VA   148.7080gon
HA   352.4228gon
Pt#  P01
OK
  
```

Press F4[REC] to input the point number, target height and code: scroll to second page through the {Func} key and press F1[OK] to save data.

```

REC  Free 44000
Tgt.H 1.45ft
Code  NO
P2
OK
  
```

You could press F1[AUTO] to perform this process directly if Pt#, code and Tgt.H are unnecessary to re-set.

Repeat the previous step to collimate and collect other points angle data

9.3. Collect points

```

REC  JOB1      P1
1.Occ. data
2.Angle data
3.Collect Points
4.Note
5.View
  
```

Select "3. Collect Points".

```

REC  Free 43997
N    5.000
E    5.000
Z    5.000
Pt#  D10      P1
AUTO DIST OFST
  
```

Aim at the target and press F2[DIST] to measure distance, and then [REC] will display at the last line.

```



REC  Free 43997
N    5.000
E    5.000
Z    5.000
Pt#  D10      P1
AUTO DIST OFST REC
  
```

Press F4[REC] to input the point number, target height and code: scroll to second page through the {Func} key and press F1[OK] to save data.

REC	Free 43997	P2
Code S		
Tgt.H	45.000m	
OK		

You could press F1[AUTO] to perform this process directly if Pt#, code and Tgt.H are unnecessary to re-set.

Aim at other targets, repeat the previous step to collect other points.

REC	Free 43997	I
SD	5.000m	
VA	302.5432gon	
HA	0.0000gon	
Pt#	D10	P1
AUTO DIST OFST REC		



Pressing the {Func} key, the screen will switch between coordinate mode and distance mode.

NOTE: Measured distance and coordinate data are recorded simultaneously.

9.4. Record note

REC	JOB1	P1
1.Occ. data		
2.Angle data		
3.Collect Points		
4.Note		
5.View		

Select "4.Note".

REC/Note	Free 13996	
ROAD100		
		
OK		

Input note and press F1[OK] to save. The max length is 60 characters.

9.5. View data

```

REC JOB1 P1
1.Occ. data
2.Angle data
3.Collect Points
4.Note
5.View
  
```

Select "5. View".

```

Stn J2
Dist J3
Coord J3
Dist J4
Coord J4
↑ ↓ .P TOP LAST SRCH
  
```

All recorded data of the active JOB will display.

Press F1[↑↓.P] key to change the function of ▲/▼ keys: if it is light, press ▲/▼ to move cursor between adjacent points; if it is back light, press ▲/▼ key to move cursor to display adjacent pages.

Press F2[TOP] key to move cursor to first point and F3[LAST] key to move cursor to last point.

Press F4[SRCH] key to enter the Point ID (PT#) to look for the point.

Select one and press {ENT} key to view, press {Esc} back to list.

```

SD 3.133m
VA 84° 39' 42"
HA 352° 28' 59"
Pt# J4
Tgt.H 1.45ft
NEXT PREV
  
```

NOTE: If the point number is the same, only the newer recorded data could be viewed.

9.6. Job selection

```

REC JOB1 P1
1.Occ. data
2.Angle data
3.Collect Points
4.Note
5.View
  
```

In "REC" menu press the {Func} key to turn to second page.

```

REC JOB1 P2
1. JOB select
  
```

Select "1.JOB select" to set job.

```

JOB selection
: JOB2
S.F. =1.000000
Coord search JOB
:JOB3
LIST S.F.
  
```

Refer to 10.1.1. Select a job to operate.

10. Data management

10.1. Job management

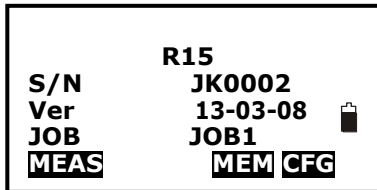

In the status mode, press F3[MEM] key to enter the memory management.

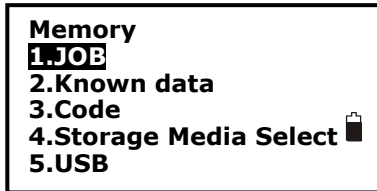

Select "1.JOB".

10.1.1. Select a job

The active JOB or coordinate search JOB could be selected. The data (known data, measured data, occupied data, coordinates, note, etc.) are recorded in the active JOB, and user can search and read coordinate in the coordinate search JOB when coordinate measuring, resection or stake out.

NOTE:

- There are 20 JOBS in total, the factory default setting is "JOB1".
- The default names are "JOB1", "JOB2", ..., "JOB20"; you can rename them if necessary.

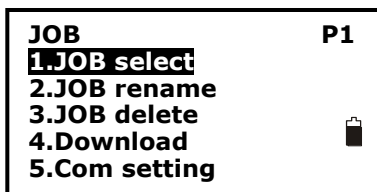

Select "1. JOB select".

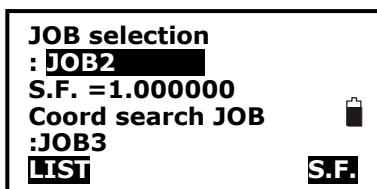

It is possible to set an active JOB (where all measured data will be saved) and a coordinate search JOB.

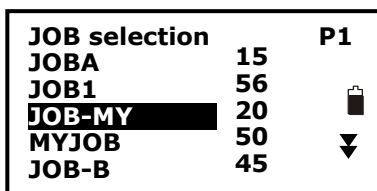

Press F1[LIST] to display all jobs on three pages. The numbers to the right represent the number of data items in each JOB. Select the job and press {ENT} key to save the setting.

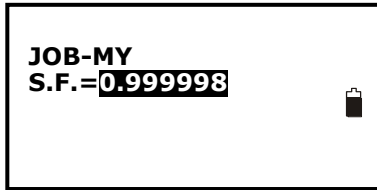

Press F4[S.F.] to modify the scale factor (factory default value is 1).
 Scale factor could be set for every JOB, but only the one of the active JOB could be modified. Here is the equation used to calculate the data:

$$HD2 = HD1 \times S.F.$$

Where:

HD2: corrected horizontal distance

HD1: measured horizontal distance

S.F.: scale factor (range: 0.5000000 ~ 2.000000).

Press {ENT} key to save the setting.

10.1.2. Rename a job

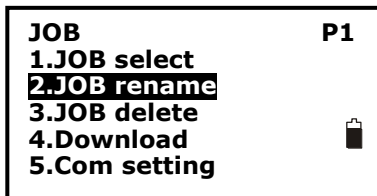

Select "2. JOB rename" to rename the active JOB.

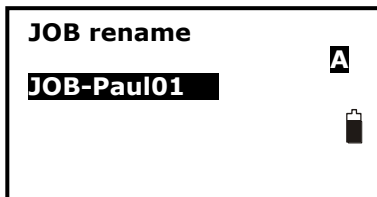

Input a new name and press {ENT} key to save the setting. The maximum length of a JOB name is 12 characters.

10.1.3. Delete a job

It is possible to delete an existed JOB. Once the JOB has been deleted with the recorded data cleared, the JOB name returns to the default one.

JOB	P1
1.JOB select	
2.JOB rename	
3.JOB delete	
4.Download	
5.Com setting	

Select "3. JOB delete".

JOB deletion	P1
JOBA	15
JOB1	56
JOB-Paul01	20
MYJOB	50
JOB-B	45

20 JOBs display on three pages. The numbers to the right represent the points quantity recorded in each JOB. Select the useless JOB that you want to delete and press {ENT} key.

JOBA	
Confirm to delete?	
NO YES	

Press F3[NO] to give up or press F4[YES] to delete the JOB.

10.1.4. Output job data

Measured data, occupied data, known point data, note and coordinates data existed in all JOBs could be outputted to PC via serial port.

NOTE: Be sure the communication port setting of instrument and PC is the same. Refer to 5.3.3. Communication port setting. In the same way, you can select the parameter using the following path from the status mode [MEM]/1.JOB/5.Com setting.

JOB	P1
1.JOB select	
2.JOB rename	
3.JOB delete	
4.Download	
5.Com setting	

Connect your instrument and computer via RS-232C port communication cable.

Select "4. Download" to enter "Com output" mode and all JOBs display.

Com output	P1
JOBA	15
JOB1	20
JOB-Paul01	50
MYJOB	45
JOB-B	56

Select the JOB to be output.

```

Com output

Searching 1
Sending 0
  
```

Press {ENT} key to start to send out; it will back to JOB list mode after finishing.

10.1.5. File copy

It is possible to copy the job from current internal memory to SD card.

```

JOB P2
1.File Copy ▲
  
```

In the second page of the JOB menu, select "1. File Copy".

```

JOB Copy P1
JOBA 15
JOBCDD 56
JOB-Paul01 20
MYJOB 50
JOB-B 45
  
```

The job list for current memory are displayed. Select one job you want to copy and press {ENT} key to confirm.

```

JOBCDD
Confirm to Copy?
NO YES
  
```

Press F3[NO] to give up or press F4[YES] to copy.

10.2. Known data management

You could input or delete coordinates of known point in the active job by key entry or entry from PC. The existed data you have input beforehand could be used as occupied point, back sight point, coordinates of known point or stakeout point. The memory is 60000 points in total.

```

R15
S/N      JK0002
Ver      13-03-08
JOB      JOB1
MEAS    MEM CFG
  
```

In the status mode, press F3[MEM] key to enter the memory management.

```

Memory
1.JOB
2.Known data
3.Code
4.Storage Media Select
5.USB
  
```

Select "2. Known data".

```

JOB selection      P1
DAFENG            10
JOBFF             3000
WOMENSHI         1256
FATELU            100
JOB6            0
  
```

Select one Job you want to operate, press {ENT} key to confirm. The numbers to the right represent the points quantity recorded in each.

```

JOB  JOB6
1.Key input
2.Com input
3.Delete
4.View
5.Clear
  
```

10.2.1. Input known point coordinate by keys

```

JOB  JOB6
1.Key input
2.Com input
3.Delete
4.View
5.Clear
  
```

Select 1.Key Input.

```

Free 45912
Pt#   S1
N     10.500
E     11.544
Z     100.000
OK
  
```

Input point number (Pt#) and coordinates. Press F4[OK] to save settings and continue to input other points. Press {ESC} key to go back to the known data mode.

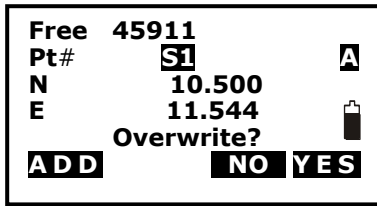

Once the Pt# is the same as an existed one, it will display as shown left.

Here:

Press F3[NO] to re-input;

Press F4[YES] to overwrite;

Press F1[ADD] to save, and the original one will not be deleted.

10.2.2. Input known point coordinate via RS-232C

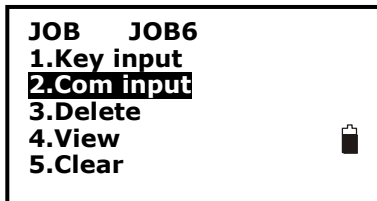

Connect instrument and PC via RS-232C communication cable.

Select "2.Com input".

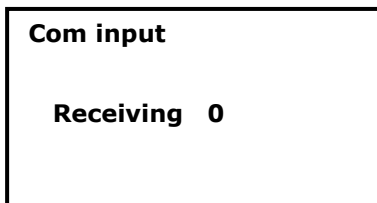

When data transferring, the number following "Receiving" will upgrade continually, at last it will back to known data mode after finishing.

NOTE: Be sure the communication port setting of instrument and PC is the same. Refer to 5.3.3. Communication port setting. In the same way, you can select the parameter using the following path from the status mode [MEM]/1.JOB/5.Com setting.

10.2.3. Delete known point coordinate

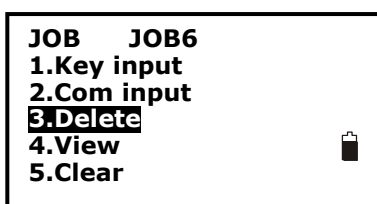

Select "3.Delete" and all known points in current JOB will display.

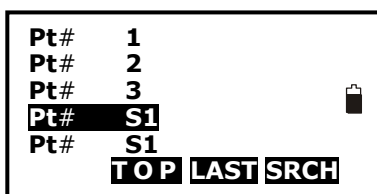

Select a point you want to delete and press {ENT} key.

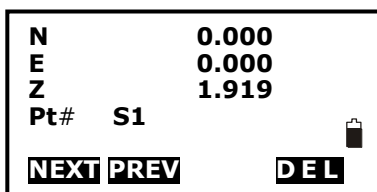

The coordinates of the selected point are displayed: press F1[NEXT] key to display the next point data, F2[PREV] to display the previous point data. Press F4[DEL] to delete it or {ESC} key to go back to known data management mode.

10.2.4. View known points data

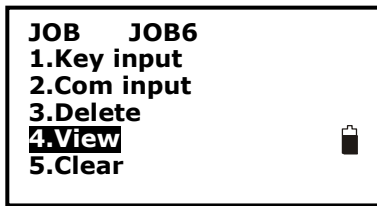

Select "4.View" and all known points of the current JOB will display.

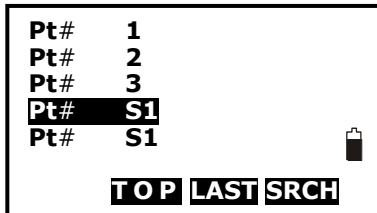

Select a point you want to delete and press {ENT} key.



The coordinates of the selected point are displayed: press F1[NEXT] key to display the next point data, F2[PREV] to display the previous point data. Press F4[DEL] to delete it and continue to delete other points or {ESC} key to go back to known data management mode.

10.2.5. Clear all known points' data

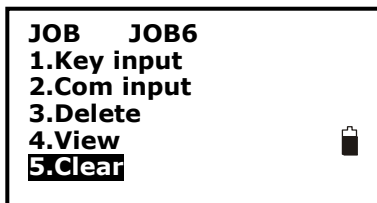

Select "5.Clear".

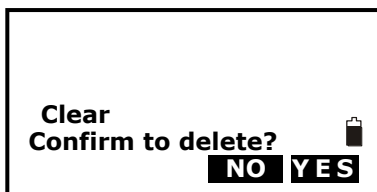

Press F3[NO] back to known data management.

Press F4[YES] to delete all known points data of the active JOB completely.

10.3. Code management

You could edit codes in this mode. All existed codes in memory could be read for all jobs, and the selected code could be recorded together with occupied data or measured data.

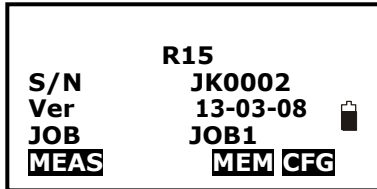

Select [MEM] in the status mode to enter memory management.

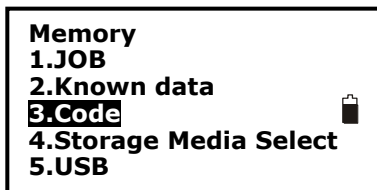

Select "3.Code" to enter the code management.



10.3.1. Edit code



Select "1.Code Edit", the code will display.

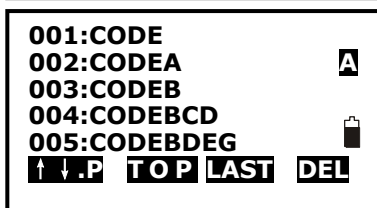

Press ▲/▼ keys to move the cursor, and input or correct code.

Here:

Press F1[↑↓.P] key to change the function of ▲/▼ keys, if it is light, press ▲/▼ to move cursor between adjacent codes. If it is back light, press▲/▼ keys to move cursor to display adjacent pages.

Press F4[DEL] key to cancel the selected code.

NOTE:

- The codes recorded in memory could be read for all JOBS.
- The max length of code is 16 characters
- 50 codes can be inputted.

10.3.2. Clear all codes



Select "2.Clear list".



Press F3[NO] back to previous mode;

Press F4[YES] to delete all codes recorded in memory of all jobs completely.



If you select "1.Code Edit", you will find no code inside.

10.4. Storage media select

For R15 series, SD card slot is a standard equipment, user can record the measured data in internal memory or SD card directly. Before your work, it is necessary select appropriate storage media. For both memory, the file management procedures are same.

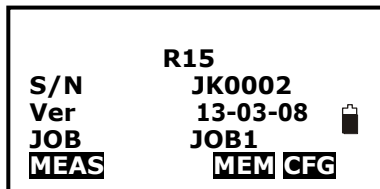

Select [MEM] in the status mode to enter memory management.

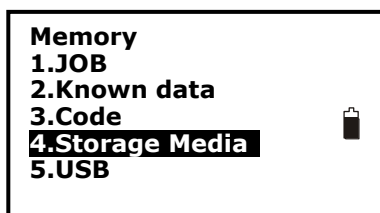

Select "4. Storage Media Select" to enter storage media setting screen.



Press "F1: Internal MSD" to set the internal card as current storage media.
Or press F2: External SD to set the external SD card as current storage media.

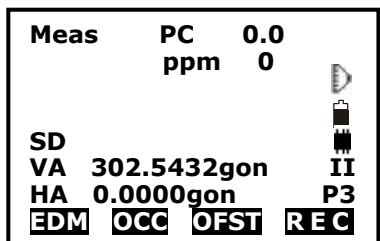

If the internal card is current storage media, the symbol  will display on screen right

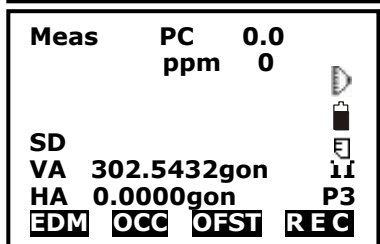

If the external SD card is current storage media, the symbol  will display on screen right.

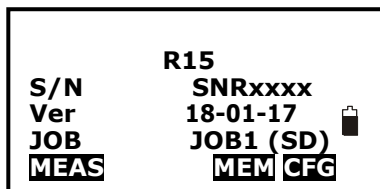

On the main page, instead, the "SD" writing appears on the side of the selected job only in the case when the external SD card is current storage media.

NOTE:

- If the SD card is first using on the total station, when select it as storage media, "Initialing" will take about 30s.

- If there is no SD card in the card slot, if you select F2: External SD, <NO SD CARD> will display.
- At power on mode, if you insert or pull out the SD card, <SD INSERT> or <SD is pulled out> will display, but these operations are not recommended.
- All the menu for internal memory or external SD card are same.

10.5. Connect PC via USB port

R15 is equipped with USB port, you can connect it with PC for data transferring.

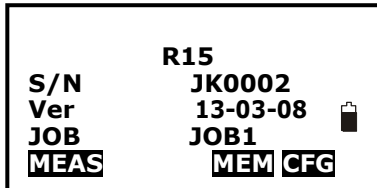

Select [MEM] in the status mode to enter memory management.

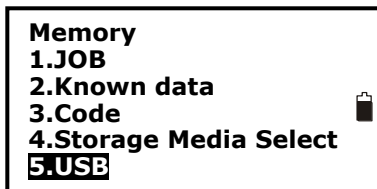

Select "5.USB" to enter USB port connecting screen.

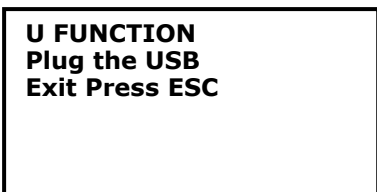

Connect instrument and PC via USB cable, it will display "U FUNCTION. Stop Press ESC".

It means the R15 is connected with PC already.

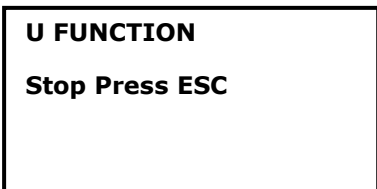

Press [ESC] to disconnect them, and the instrument goes back to previous menu.

11. Check and adjustment

11.1. The instrument constant

I. Check

It is suggested to observe and compare the instrument with a testing baseline which is set on stable ground with a particular accuracy, though error is not generally included in the instrument constant. If the testing line is unavailable, you can select a flat place and set up the instrument and a target at the same height.

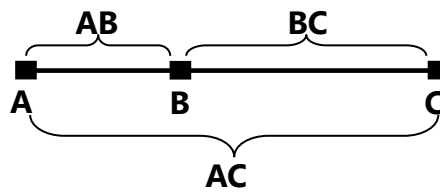

1. Select a point B on the approximately horizontal line AC with about 100 meters long. Measure the distances of lines AB, AC and BC.
2. The instrument constant can be calculated:

$$\text{Instrument constant} = AB + BC - AC$$

3. Repeat steps 1 and 2 ten times, and get the average value for instrument constant, if the average value is within $\pm 3\text{mm}$, adjustment is unnecessary.
4. If the difference is over $\pm 3\text{mm}$ after the preceding operations, it is necessary to reset the instrument constant.

II. Adjustment

If it is necessary to reset the instrument constant, please contact STONEX service representative to perform that.

11.2. Plate level

I. Check

1. Mount the instrument on a stable device (as tripod, adjusting device) and fix it.
2. Level the instrument until the plate level is parallel to a line linking leveling foot screws A and B, then adjust the two screws to center the bubble.
3. Turn the instrument $180^\circ/200\text{gon}$, observe the moving direction of the bubble, if it is still centered, no adjustment is necessary, if not, you have to adjust it.

II. Adjustment

1. Mount the instrument on a stable device and fix it.
2. Level it roughly.
3. Turn the instrument and make the tubular level be parallel to a line linking two leveling foot screws, then adjust the two screws to center the bubble.
4. Turn the instrument $180^\circ/200\text{gon}$, adjust the Adj-screw with adjustment pin slightly to correct half of the bubble's displacement when it doesn't move.
5. Repeat operations 3, 4 until the bubble remains centered in any position.

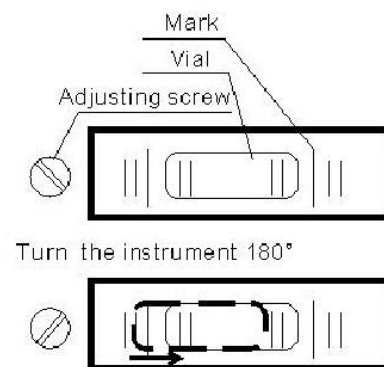

11.3. Circular level

I. Check

- a. Mount the instrument on a stable device and fix it.
- b. Level it accurately by the plate level.
- c. Observe the bubble of the circular level, if it is centered, no adjustment is necessary, if not, you have to adjust it.

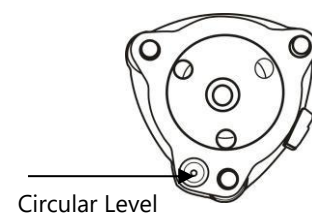

II. Adjustment

- Mount the instrument on a stable device and fix it.
- Level it accurately by the plate level.
- Adjust the three adj-screws to center the bubble by a wrench.

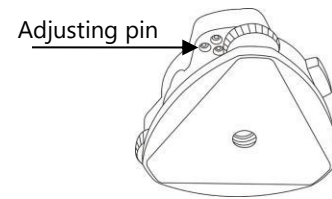

NOTE: Be careful when adjusting the three screws, and the tightening tension is identical for them.

11.4. The optical sight

I. Check

- Mount the instrument on a tripod and fix it.
- Set a cross mark target which apart from the instrument about 50m.
- Take the telescope sight the cross mark.
- Observe the optical sight collimator whether collimating the cross mark, if collimate the mark, adjustment is not necessary; if not, adjust it.

II. Adjustment

- Mount the instrument on the tripod and fix it.
- Set a cross mark target which apart from the instrument about 50m.
- Take the telescope sight the cross mark. Loosen two fixing screws, adjust and fix the two screws again.

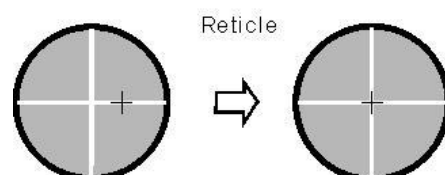
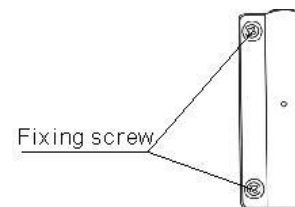

11.5. Laser plummet

I. Check

1. Set the instrument on stable device and fix it.
2. Set a cross mark on the ground under the instrument.
3. Turn the three leveling screws until the instrument keeps leveling and the laser spot coincides with the cross mark on the ground.
4. Rotate the instrument 180°(200gon) around and check the laser spot and cross mark if they coincide, adjustment is not required. Otherwise, adjust it.

II. Adjustment

1. Set the instrument on stable device and fix it.
2. Set a cross mark on the ground under the instrument.
3. Turn the three leveling screws until the instrument keeps leveling and the laser spot coincides with the cross mark on the ground.
4. Rotate the instrument 180°(200gon) around and take off the protecting cover of the laser plummet, adjust the three adjusting screws with the screwdriver to move the laser spot to the cross mark, correct only one-half of the displacement in this manner.
5. Repeat operations 3 and 4 until the instrument keeps leveling and the laser spot coincides with the cross mark when rotating alidade of instrument to any direction.



11.6. Vertical cross-hair on telescope

I. Check

1. Set the instrument up the tripod and carefully level it.
2. Set a point A front the instrument 50m apart.
3. Collimate the point A and adjust the vertical tangent screw; If the point appears to move continuously on the hair, adjustment is not required. Otherwise, adjust it.

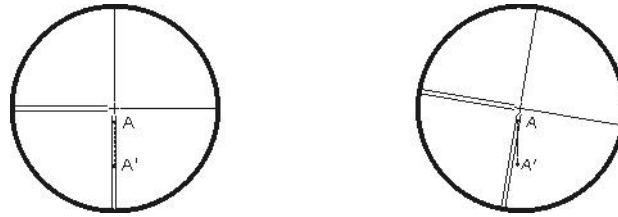

II. Adjustment

1. Set the instrument and set the point A front the instrument 50m apart.
2. Take off cover of telescope eyepiece, there are 4 screws for the reticle part.
3. Loosen all four fixing screws slightly with the cross screw-driver.
4. Revolve the eyepiece section so that the vertical cross-hair coincides to point A, finally, re-tighten the four screws.
5. Repeat the checking and adjusting until there is no deviation.

NOTE: After the adjustment of cross-hair, please check the collimation error and vertical index error, see 11.10. EDM optical axis and the telescope sighting axis error.

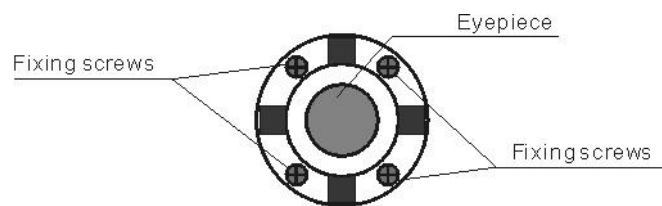

11.7. Tilt sensor

If the tilt angle shown on the display shifts from tilt angle 0° (zero point), the instrument is not correctly leveled. This will adversely affect angle measurement. Perform the following procedures to cancel the tilt zero-point error.

I. Check

Wait a few seconds for this display to stabilize, then read the automatically compensated angles X1 and Y1.

Rotate the instrument 180°/200 gon. Wait a few seconds for the display to stabilize, then read the automatically compensated angles X2 and Y2.

Calculate the following offset values (tilt zero-point error):

$$X_{offset} = \left(\frac{X1 + X2}{2} \right)$$

$$Y_{offset} = \left(\frac{Y1 + Y2}{2} \right)$$

When the offset value falls within the range $\pm 20''$, adjustment is not necessary. If one of the offset values (Xoffset, Yoffset) exceeds $\pm 20''$, adjust the value as follows.

II. Adjustment by program

R15	
S/N	SNRxxxx
Version	18-05-29
Job	JOB1
MEAS	MEM CFG

In the main page, press F4[CFG] to enter the configuration menu.

Configura	
1.Meas condition	
2.Inst. config	
3.Inst. adjust	
4.Com setting	
5.Unit	

Select "3.Inst. adjustment".

Inst. adjust	
1.Tilt Correct	
2.V-Index	
3.Hz-Collimation	
4.Parameter View	

Select "1.Tilt Correct".

X	-0.0020gon
Y	-0.0003gon
HA	127.1202gon
Take F1	
OK	

Sight the cross point in face I and press F3[OK] key.

X	0.0008gon
Y	-0.0012gon
HA	127.1202gon
Take F2	
OK	

Sight the cross point in face II and press F3[OK] key.

X Old	0.0020gon
Y Old	0.0010gon
X New	0.0006gon
Y New	0.0012gon
Set?	
YES NO	

If both the correction constants are acceptable, press the F3[YES] key to set the correction, or F4[NO] to give up.

11.8. Horizontal collimation error C

If the telescope's sight line isn't perpendicular to the horizontal axis, the collimation error will appear. The assembling, transportation and operation will cause this error.

I. Check

1. Set-up the instrument on tripod or adjustment platform and leveling accurately.
2. Aim at the cross-hairs of collimator or the obvious target at a distance. Gets the face left angle reading Hl and the face right angle reading Hr.
3. Calculating the horizontal collimation error C according to:

$$C = \frac{Hl - Hr \pm 180^\circ}{2}$$

if $C < 8''$, no adjustment will be necessary. If $C > 8''$, proceed with the following adjustment.

II. Adjustment by program

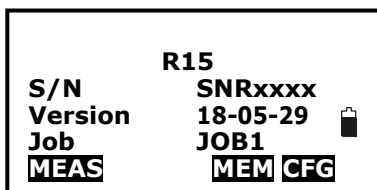

In the main page, press F4[CFG] to enter the configuration menu.

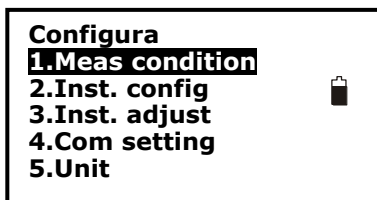

Select "3.Inst. adjustment".

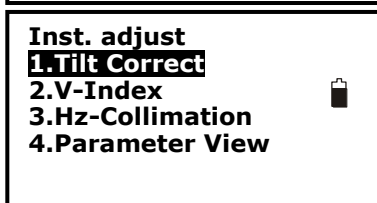

Select "3.Hz- Collimation".

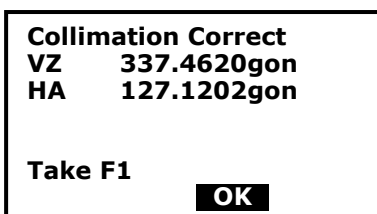

Sight the cross point in face I and press F3[OK] key.

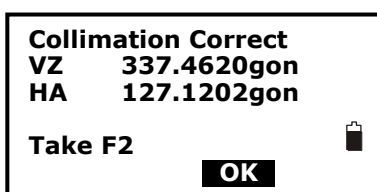

Sight the cross point in face II and press F3[OK] key.

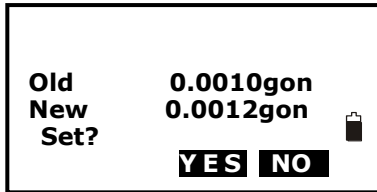

If the correction constant is acceptable, press the F3[YES] key to set the correction, or F4[NO] to give up.

NOTE: The adjustment can be performed by the program when $C < 30''$, if $C > 30''$, adjust the reticle.

III. Reticle adjustment

- a. Rotate the instrument in face right position, turning horizontal tangent screw until:

$$Hr' = Hr + C$$

- b. Loosen the shield of telescope's reticle.
- c. Adjust two screws at left and at right until the vertical hairs of telescope's reticle coincides with the cross-hairs of collimator or target.

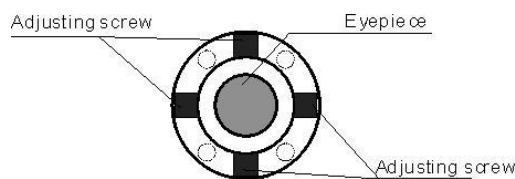

4. Repeat the check and adjustment procedure until the error is accepted.

NOTE:

- When adjusting the screws of reticle, firstly loosen the screw on the moving direction of reticle, secondly tighten another screw by the same mount, clockwise turning is for tightening, and anticlockwise turning is for loosening, the turning mount for tightening or loosening should be same.
- After the reticle adjustment, it is necessary to adjust the vertical index error by program, see 11.9. Vertical index error.

11.9. Vertical index error

The deviation between vertical circle zero position and horizontal direction is vertical index (i), it is necessary to concern this error when measure vertical angle. The instrument program applied a formula to correct this error.

WARNING: Before starting this operation, be sure to read this manual carefully, otherwise it may cause data faulty. Because of the close relationship between vertical index and compensator zero position, it is necessary to check and adjust compensator zero position before adjusting vertical circle, the value should be stable when reading.

I. Check

Please adjust the reticle of telescope and correct the collimation error before this operation.

1. Mount the instrument at the tripod or a stable device and level it accurately, then turn on the instrument.
2. Aim at the cross-hairs of collimator or the obvious target at a distance, VA should be about $\pm 10^\circ$. Read the face left angle Vl and face right angle Vr .
3. Calculate the index error according to the formula below:

$$i = \frac{(Vl + Vr - 360^\circ)}{2}$$

4. If $i < 10''$, no adjustment is necessary, otherwise you have to adjust it.

II. Adjustment by program

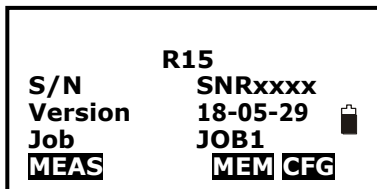

In the main page, press F4[CFG] to enter the configuration menu.

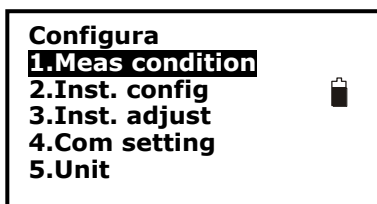

Select "3.Inst. adjustment".

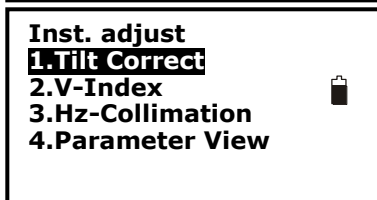

Select "2.V-Index".

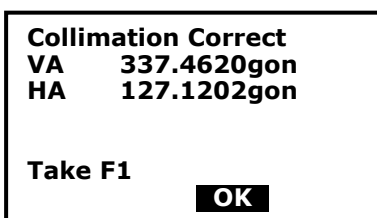

Sight the cross point in face I and press F3[OK] key.

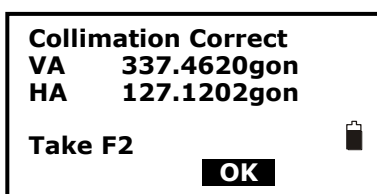

Sight the cross point in face II and press F3[OK] key.

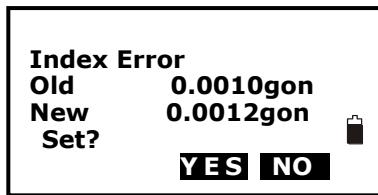

If the correction constant is acceptable, press the F3[YES] key to set the correction, or F4[NO] to give up.

11.10. EDM optical axis and the telescope sighting axis error

It is necessary to check this error after the adjustment of telescope reticle error.

I. EDM optical axis check

1. Install the instrument at the tripod or a stable device and level it accurately, then turn on the instrument's power on.
2. Set a prism about 2m far away from the instrument.
3. Aim at the prism center with telescope reticle
4. Enter EDM signal testing screen, see 5.2. EDM settings.
5. Observe through eyepiece, turn the focusing knob until the read mark is clear, if the deviation between mark and cross-hair is not over 1/5 of red mark diameter, adjustment is unnecessary.

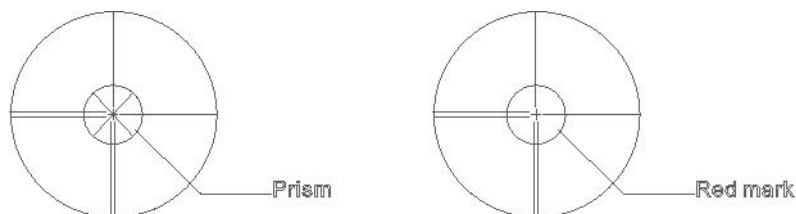

II. Telescope sighting axis error check

1. Install the instrument at the tripod or a stable device and level it accurately, then power on the instrument.
2. Set a reflective sheet about 5m-20m far away from the instrument.
3. Aim at the sheet cross-mark with telescope reticle.



5. Enter EDM signal testing screen, see 5.2. EDM settings

6. Observe the laser spot, if the laser spot coincides with the cross-mark of reflective sheet, adjustment is unnecessary.

NOTE:

- Laser radiation—Avoid direct eye exposure.
- If the instrument needs adjustment, please contact your local dealer.

12. Warning and error messages

“Low Signal!”

Please accurately re-sight the target.

“Same coordinates”

The coordinates of the back sights are the same, please re-define or re-input.

“Out of value”

The difference value of coordinates is over range

“Out of range”

The stake out height is over range.

“Need 1st obs”

During missing line measurement, the observation of the starting position was not completed normally. Sight the starting position accurately and press [OBS] to perform the measurement again.

“Change 1st obs?”

During missing line measurement, the observation of the target was not completed normally. Sight the target accurately and press [MLM] to perform the measurement again.

“Need prism obs”

During REM measuring, the observation of the target was not completed normally. Sight the offset point accurately and press [MEAS] to perform the measurement again.

“No Free Space!”

There is no more space to enter data. Record the data again after deleting unnecessary data from the JOB or coordinate data from memory.

“No data”

When searching for coordinate data or searching for code data, the search stopped either because the item in question does not exist or the data volume is large.

13. Technical features

ANGLE MEASUREMENT

Accuracy ¹	2"
Reading system	Absolute encoder
Display resolution (selectable)	1" /5" /10" 0.0002g/0.001g/0.002g 0.005mil/0.02mil/0.05mil
Angle Units	DEG 360°/GON 400/MIL 6.400

TELESCOPE

Magnification/ Field of view	30x/1°30'
Tube length	156 mm
Minimum focus distance	1.0 m (3.26 ft)
Reticle	10 brightness levels adjustable
Objective aperture	φ 45 mm
Laser pointer	Red light, coaxial

TILT SENSOR

Type	Electronic, dual-axis
Compensation range/accuracy	± 3.0'/1"

DISTANCE MEASUREMENT RANGE²

Standard mode prism	3.000 m ³
Long mode prism	5.000 m ⁴
Reflective sheet (6cm x 6cm)	800 m ⁴
Reflectorless	600 m ⁴

DISTANCE MEASUREMENT ACCURACY⁵

Standard mode prism	2 mm + 2 ppm
Long mode prism	2 mm + 2.5 ppm
Reflective sheet (6cm x 6cm)	3 mm + 2 ppm
Reflectorless	3 mm + 2 ppm

MEASUREMENT TIME

Standard mode/Prism (Tracking/Fast/Fine)	0.4/0.6/1.0 sec
Reflectorless	1.5±5 sec

DISTANCE MEASUREMENT

Distance Unit	m/US ft/INT ft
Display Resolution (selectable)	0.0001m/0.001m 0.001ft/0.01ft

LASER PLUMMET

Laser type	635nm semiconductor laser
Accuracy	1mm/1.5 m
Spot	± 1.5mm/1.5 m

LEVEL VIAL SENSITIVITY

Plate level	30"/2mm
Circular level	8'/2mm

ENVIRONMENTAL CONDITIONS

Operating Temperature	-20° C +50° C
Storage Temperature	-40° C +70° C
Waterproof/Dustproof	IP55

PHYSICAL SPECIFICATION

Dimensions	202 x 197 x 345 mm
Weight including battery and tribrach	5.5 Kg

POWER

Battery Voltage/Capacity	7.4V/3.400mAh Li-ion
Operating time (angle measurement)	24 hours
Operating time (distance meas. every 30 sec)	12 hours
Operating time (angle + distance meas.)	10 hours
Battery charger	110/220V, charging time 4h

OTHER SPECIFICATIONS

Display/Keyboard	Two sides, LCD 96x160 Dots/Alphanumeric
Memory	120.000 points SD card (max 16Gb)
Interface	RS-232C/mini USB/SD card/ Bluetooth
Sensor	Temperature/Pressure

ON BOARD FIELD APPLICATION PROGRAMS

Data recording and management, Stake out, Area, Offset, Traverse, Inverse, Point projection, MLM, REM, Resection, Line stake out, Arc stake out, Polarize, Repeat measure, Road calculation

Specifications subject to change without notice.

¹ Standard deviation based on ISO 17123-3

² Good condition: no haze, visibility about 40km, no heat shimmer, breeze. Under optimal conditions on Kodak Grey Card (90% reflective)

³ Class 1

⁴ Class 3R

⁵ Standard deviation based on ISO 17123-4

14. Kit components

- R15 Series Total Station
- Carrying case
- Carrying strap x2
- Battery x2
- Battery charger
- USB communication cable
- Lens cap
- Tools kit
- Cleaning cloth
- User Manual
- Reflective sheet/RP30 x4
- Reflective sheet/RP60
- Laser caution sign board
- Silica gel
- Certification

Appendix I: Atmospheric correction formula and chart

Factory setting: temperature: 20°C, pressure: 1013hPa, 0ppm

The correction:

$$K_{pt} = \frac{274.417 - 0.2905 \cdot p}{(1 + 0.0036 \cdot t)}$$

$$K_{pt} = \frac{278.960 - 0.2902 \cdot p}{(1 + 0.0036 \cdot t)}$$

Where:

p: Pressure value (hPa)

t: Temperature value (°C)

Kpt: Atmospheric correction (ppm)

Example:

t=20°C, p=1013hpa, L0=1000m.

Then: Kpt=0ppm

Kpt=4ppm

$L=L_0(1+K_{pt})=1000 \times (1+0 \times 10^{-6})=1000.000m$

$L=L_0(1+K_{pt})=1000 \times (1+4 \times 10^{-6})=1000.004m$

The atmospheric value is obtained easily with the atmospheric correction chart. Find the measured temperature in horizontal axis, and pressure in vertical axis on the chart.

Read the value from the diagonal line, which is the required atmospheric correction value.

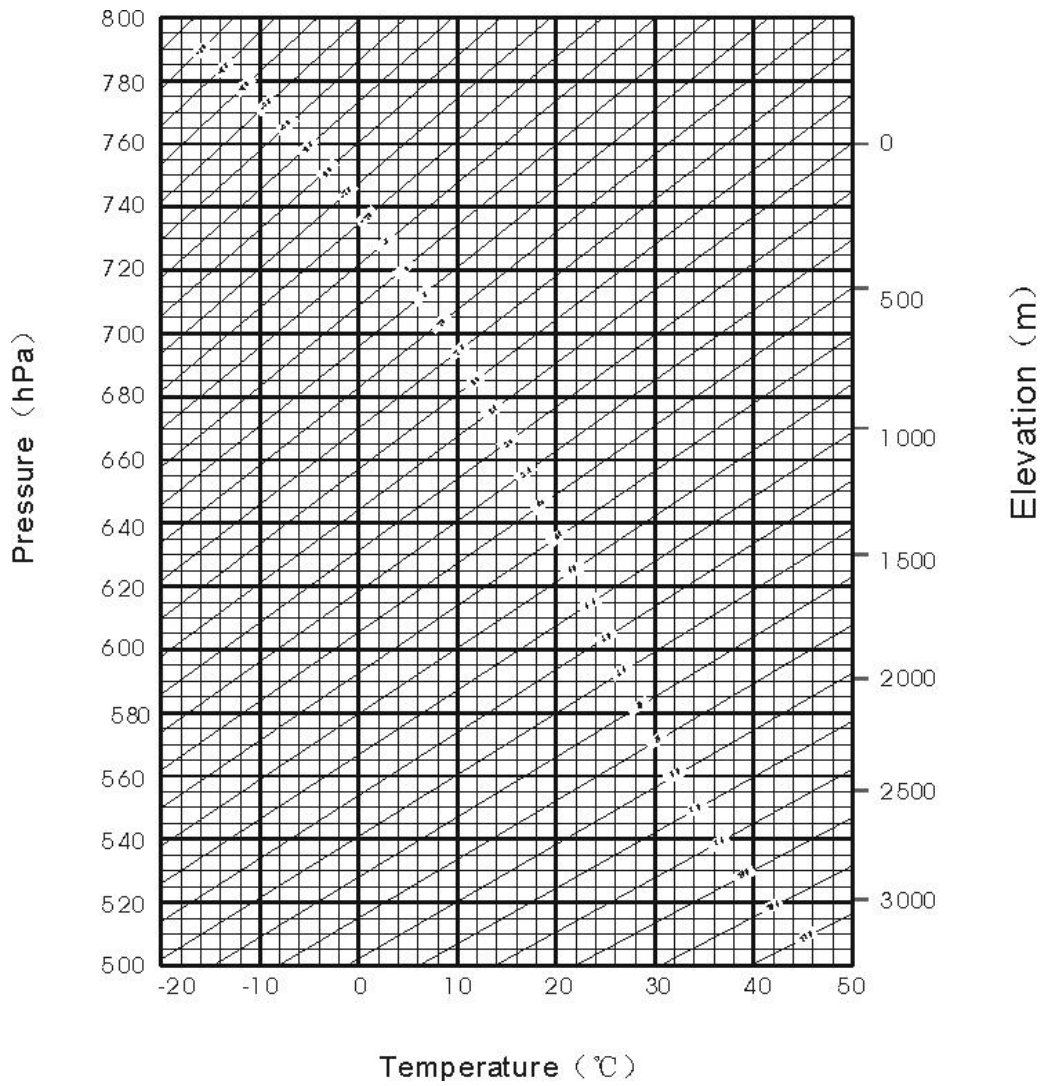
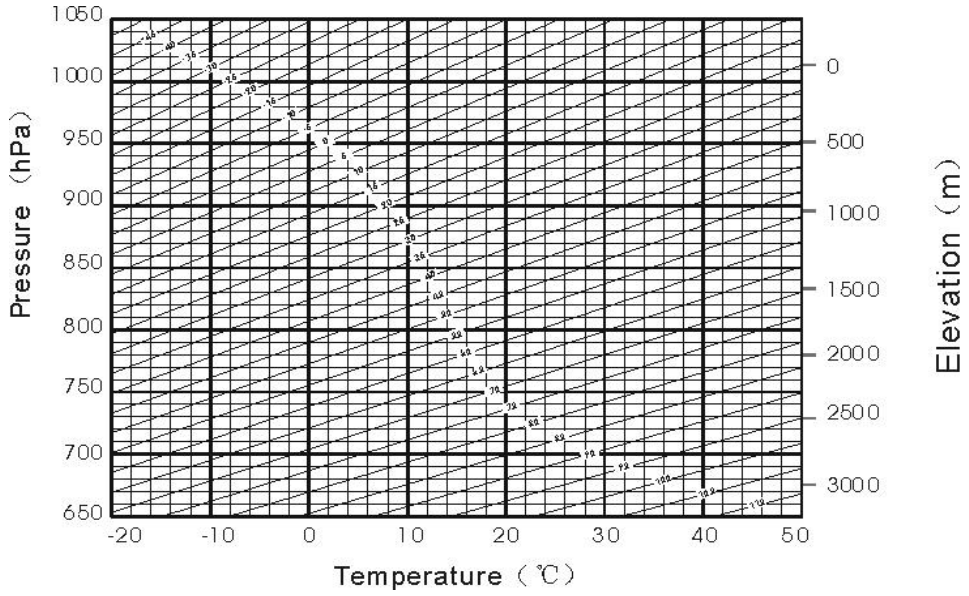

Appendix II: Correction for refraction and earth curvature

The factory setting for the refraction coefficient K is 0.142.

Considering the correction of refraction and earth curvature for distance measurement, the formula for slope distance, horizontal distance and vertical distance applied in the instrument are as followings:

$$SD = D_0 \times (1 + ppm \times 10^{-6}) + mm$$

SD — Displayed slope distance (m)

D_0 — Real measured distance (m)

ppm — Scale coefficient (mm/km)

mm — Target constant (mm)

$$HD = Y - A \times X \times Y$$

$$VD = X + B \times Y^2$$

HD — Horizontal distance (mm)

VD — Vertical distance (mm)

$$Y = SD \cdot |\sin \xi|$$

$$X = SD \cdot \cos \xi$$

ξ — Zenith angle

$$A = \frac{1 - \frac{K}{2}}{R}$$

$$B = \frac{1 - \frac{K}{2}}{2R}$$

$$K = 0.142 \text{ or } 0.20$$

$$R = 6.37 \times 10^6 \text{ (m)}$$

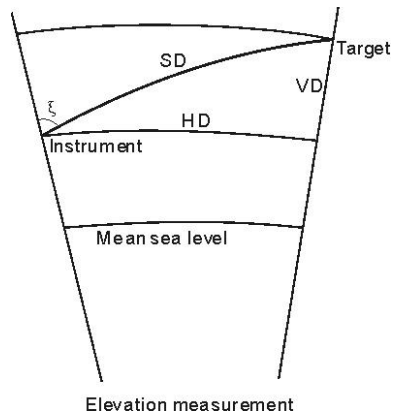

The conversion formula for horizontal and vertical distance is as follows when correction for refraction and earth curvature is not applied:

$$HD = SD \cos \xi$$

$$VD = SD |\sin \xi|$$

NOTE:

- Refer to the 5.3. How to set parameters to change the value.
- These designs, figures and specifications are subject to change without notice. We shall not be held liable for damages resulting from errors in this instruction manual.

Appendix III: Technical drawing

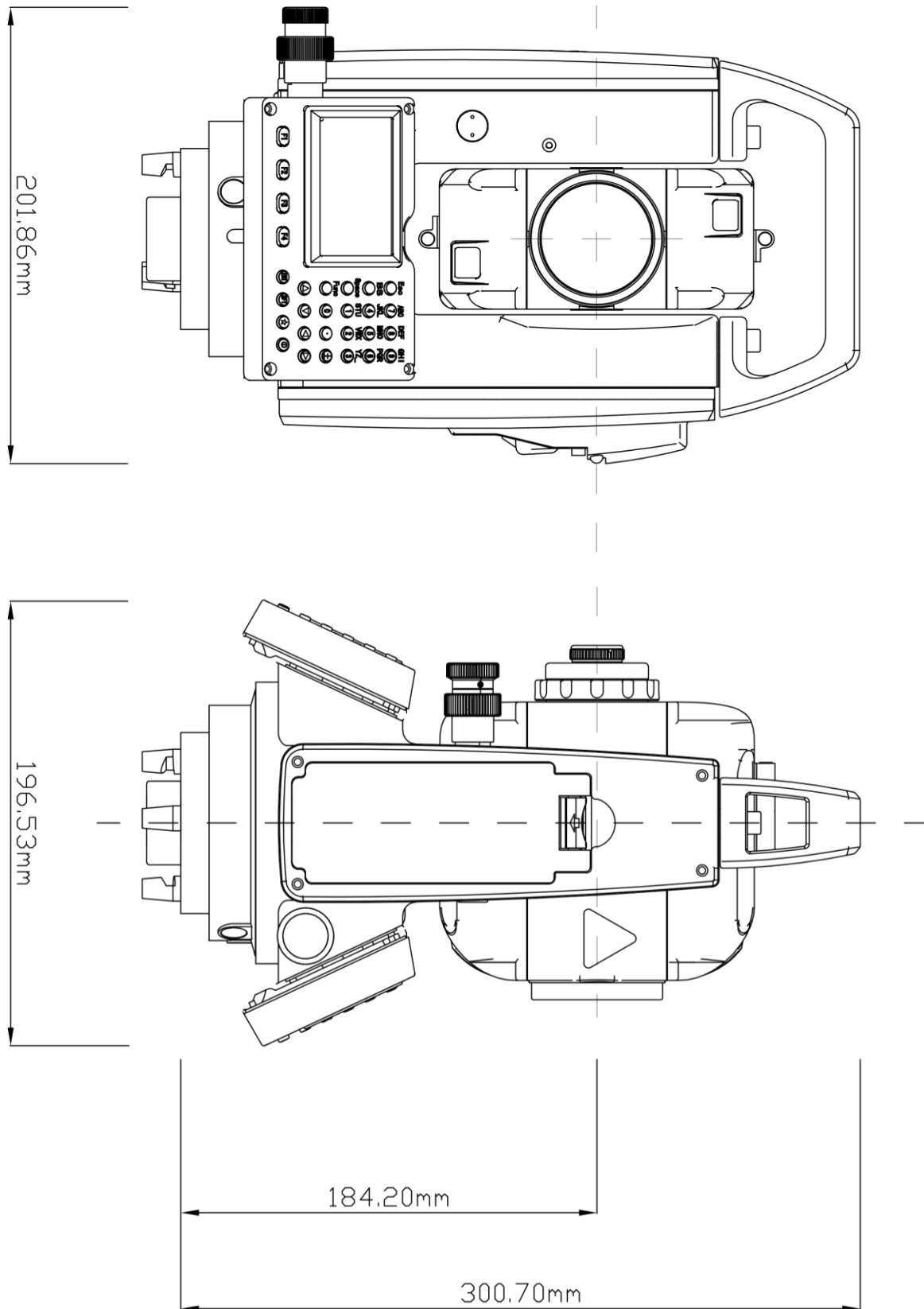

Limited warranty standard

General warranty for instruments.

The terms and conditions of this Limited Warranty constitute the complete and exclusive warranty agreement between The Customer or Dealer and STONEX® for the Product and it supersedes any prior agreement or representation made in any STONEX® sales document or advice that may be provided to Customer by any STONEX® representative in connection with Customer's purchase of the Product. No change to the conditions of this Limited Warranty is valid unless it is made in written form and signed by an authorized STONEX® supervisor.

STONEX® warrants that:

1. Products are free from defects in materials or workmanship for generally 1/2 year except for accessories or specific parts for which different limited warranty period shall apply.
2. Products have been tested/calibrated in proper working status prior to shipment.

The warranty period starts from date of first sale of the instruments. At its sole discretion, under the warranty period, STONEX® will repair the product or send parts for replacement at its expense. STONEX® agree to repair or replace the defected instrument within thirty (30) days, only if STONEX® recognizes that the defects of the instrument are not caused by human factors or no obvious damage to its surface is visible. STONEX® warrants any new replaced parts or products are warranted to be free from defects in materials and workmanship for thirty (30) days or for the remainder of the Limited Warranty Period of the Product in which they are installed, whichever is longer. Faulty Parts or Products replaced under this Limited Warranty shall become property of STONEX®.

All products that have to be repaired have to be returned to our technical representative office location via any delivery company the customer prefers.

NOTE: STONEX® is not accountable for the unlikely event that the Products gets lost in transit.

Any damage inflicted by the customer or by third party after the products has been delivered to the customer is excluded from the limited warranty as well any damage arising from an improper use, from any action or use not provided for in the enclosed user guides and/or manuals.

Shipping policy

The Customer or the dealer is required to pay for the charges for shipping of fault

parts or instruments to STONEX® representative office and STONEX® (will provide) the shipping for return. Dealers needs to follow STONEX® repair/service procedure to achieve a better and prompt service result.

Return policy dead on arrival instruments

All returned products have to be shipped to STONEX® representative office.

The original Purchaser has a period of seven (7) days, starting from date (data) of purchasing to signal the existence of a defect in the instrument for a full refund (less shipping and handling), provided the merchandise is in new, resalable condition and returned in the original, undamaged packaging. Customer has to pay for both the return and the original freight fees, regardless of the original freight paid by the Company. All warranty books, instruction manuals, parts and accessories must be included as well as the original box in which the item was shipped. We recommend to place the original carton inside another box, to avoid any additional damage to the carton itself. In some cases, returns of special items will require a re-stock fee . Acceptance of returned merchandise is final only after inspection by STONEX®.

Above terms and (policy shall apply as for hardware.) Dealers needs to follow STONEX® repair/service procedure to achieve a better and prompt service result.

Firmware/Software warranty:

Stonex doesn't warrant that operation of Firmware/Software on any instruments will be uninterrupted or error-free, or that functions contained in Firmware/Software will operate to meet your requirements.

Stonex will forward the Software/Firmware Fix to the dealer or customer. Firmware/software Fix means an error correction or other update created to fix a previous firmware version that substantially doesn't conform to the instruments specification.

Over warranty repair(s) policy.

Customer shall pay the standard repair fees for any service (whether part replacement or repairs) and performed by STONEX® under request and explicit authorization of the customer itself. In this case the customer is charged for return shipment's fees as well.

Disclaimer and limitation of remedy.

ALL OTHER EXPRESS AND IMPLIED WARRANTIES FOR THIS PRODUCT, INCLUDING THE IMPLIED WARRANTIES OF MERCHANTABILITY AND FITNESS FOR A PARTICULAR PURPOSE AND/OR NONINFRINGEMENT OF ANY THIRD PARTY'S RIGHTS, ARE HEREBY DISCLAIMED. STONEX® EXPRESSLY DISCLAIMS ALL WARRANTIES NOT STATED IN THIS LIMITED WARRANTY. ANY IMPLIED WARRANTIES THAT MAY BE IMPOSED BY LAW ARE LIMITED IN DURATION TO THE TERM OF THIS LIMITED WARRANTY. SOME JURISDICTIONS DO NOT ALLOW THE EXCLUSION OF IMPLIED WARRANTIES OR LIMITATIONS ON HOW LONG AN IMPLIED WARRANTY LASTS, SO THE ABOVE EXCLUSIONS OR LIMITATIONS MAY NOT APPLY TO CUSTOMER. CUSTOMER MUST READ AND FOLLOW ALL SET-UP AND USAGE INSTRUCTIONS IN THE APPLICABLE USER GUIDES AND/OR MANUALS ENCLOSED. IF CUSTOMER FAILS TO DO SO, THIS PRODUCT MAY NOT FUNCTION PROPERLY AND MAY BE DAMAGED. CUSTOMER MAY LOSE DATA OR SUSTAIN PERSONAL INJURIES. STONEX®, ITS AFFILIATES AND SUPPLIERS DO NOT WARRANT THAT OPERATION OF THIS PRODUCT WILL BE UNINTERRUPTED OR ERROR FREE; AS DO ALL ELECTRONICS AT TIMES. IF THIS PRODUCT FAILS TO WORK AS WARRANTED ABOVE, CUSTOMER'S SOLE AND EXCLUSIVE REMEDY SHALL BE REPAIR OR REPLACEMENT. IN NO EVENT WILL STONEX®, ITS AFFILIATES OR SUPPLIERS BE LIABLE TO CUSTOMER OR ANY THIRD PARTY FOR ANY DAMAGE IN EXCESS OF THE PURCHASE PRICE OF THE PRODUCT. THIS LIMITATION APPLIES TO DAMAGES OF ANY KIND WHATSOEVER INCLUDING (1)

DAMAGE TO, OR LOSS OR CORRUPTION OF, CUSTOMER'S RECORDS, PROGRAMS, DATA OR REMOVABLE STORAGE MEDIA, OR (2) ANY DIRECT OR INDIRECT DAMAGES, LOST PROFITS, LOST SAVINGS OR OTHER SPECIAL, INCIDENTAL, EXEMPLARY OR CONSEQUENTIAL DAMAGES, WHETHER FOR BREACH OF WARRANTY, CONTRACT, TORT OR OTHERWISE, OR WHETHER ARISING OUT OF THE USE OF OR INABILITY TO USE THE PRODUCT AND/OR THE ENCLOSED USER GUIDES AND/OR MANUALS, EVEN IF STONEX®, OR AN AUTHORIZED STONEX® REPRESENTATIVE, AUTHORIZED SERVICE PROVIDER OR RESELLER HAS BEEN ADVISED OF THE POSSIBILITY OF SUCH DAMAGES OR OF ANY CLAIM BY ANY OTHER PARTY. SOME JURISDICTIONS DO NOT ALLOW THE EXCLUSION OR LIMITATION OF INCIDENTAL OR CONSEQUENTIAL DAMAGES FOR SOME PRODUCTS, SO THE EXCLUSIONS OR LIMITATIONS MAY NOT APPLY TO CUSTOMER. THIS LIMITED WARRANTY GIVES CUSTOMER SPECIFIC LEGAL RIGHTS, AND CUSTOMER MAY ALSO HAVE OTHER RIGHTS WHICH VARY FROM COUNTRY/STATE/JURISDICTION TO COUNTRY/STATE/.

Two years on STONEX® Product:

Total Station R15 (all variants) excluding battery and power supply accessories (6 months).

Repair/Service procedure for dealers.

(1) S/N of the instrument and a detailed description of the defect (sometimes pictures or video) will be required to indicate the cause and problem.

(2) If dealer wants to repair an instrument under warranty period on their site:

1) If dealers (don't) have the part in stock they have to send an official order to STONEX® and pay for it and then so STONEX® will send the new part to them so they can repair the instrument.

2) When the repair is over dealer has to fill the "Spare Part Refund" module and send it to the dedicated mail address.

3) Wait for STONEX®'s authorization SPR no;

4) When dealer receives the SPR authorization number they can send back to STONEX® appointed office the broken part with attached the SPR module;

5) When STONEX® receive the broken part STONEX® shall verify it and if everything is ok the cost of the part shall be refund (refund will be done only after check of the failure part and final approval of STONEX®).

(3) If the instrument needs to be sent back to STONEX® for repair/replacement, dealers/customers has to send to STONEX® a "Returned Merchandise Authorization (RMA)" before they send back the fault instrument. STONEX® shall, at its sole discretion, decide on the place of performance for work under warranty.

FCC statements

Total station R15:

This device complies with part 15 of the FCC Rules. Operation is subject to the following two conditions:

- (1) This device may not cause harmful interference.
- (2) This device must accept any interference received, including interference that may cause undesired operation.

Power adapter model FDJ6-LI:

This device complies with part 15 of the FCC Rules. Operation is subject to the following two conditions:

- (1) This device may not cause harmful interference.
- (2) This device must accept any interference received, including interference that may cause undesired operation.

Environmental recycling

The cardboard box, the plastic in the package and the various parts of this product have to be recycled and disposed of in accordance with the current legislation of your Country.

FOR COUNTRIES IN THE EUROPEAN UNION (EU)

The disposal of electric and electronic device as solid urban waste is strictly prohibited: they must be collected separately.

Contact Local Authorities to obtain practical information about correct handling of the waste, location and times of waste collection centers. When you buy a new device of ours, you can give back to our dealer a used similar device.

The dumping of these devices at unequipped or unauthorized places may have hazardous effects on health and environment.

The crossed dustbin symbol means that the device must be taken to authorized collection centers and must be handled separately from solid urban waste.



FOR COUNTRIES OUTSIDE EUROPEAN UNION (EU)

The treatment, recycling, collection and disposal of electric and electronic devices may vary in accordance with the laws in force in the Country in question.



STONEX® SRL

Via Cimabue, 39 - 20851 Lissone (MB)

Tel : +390392783008 ; +390392785575 | Fax :+390392789576

www.stonex.it | info@stonex.it